

HAFCO SCA-5016P



50mm x M12 Multi-Purpose Riser/Stops (Spigot Type) - 4pc Pack



HAFCO 50mm x M12 Multi-Purpose Riser/Stops (Spigot Type) - 4pc Pack SCA-5016P



Threaded Insert

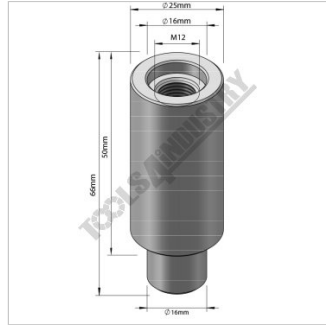

Dimensions

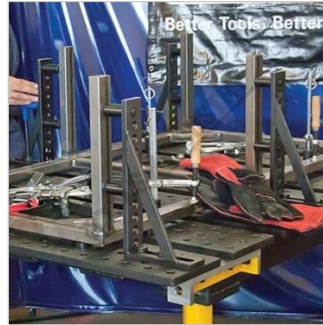

Handy and Quick to Set Up these stops can be used to Locate Stop or Position Workpieces



Quick Effective Locating and Positioning of Stock



The Stops Provide Low Profile Locating and Make Workpiece Removal Easy

Description

These stops can be inserted into welding tables with Ø16mm holes, the multi-purpose design allows them to be used as a material rest or as a stop to positive locate of your workpiece. The spigot base gives you the ability to quickly place into the welding table holes to ensure accuracy & consistency of your welding tasks.

Features

- Pin type spigot suits welding tables with Ø16mm holes
- Suits welding tables with a minimum of 6.35mm plate thickness
- Use as an extension for welding clamps to increase clamp height by 50mm
- 50mm in height from table surface & 25mm in diameter
- M12 Internal Thread

Specifications

ORDER CODE	W08517
MODEL	~
Suits Table Hole Size (Ø)	16mm
Type	Material Stop
Suits Table Thickness (mm)	6.35 Minimum
Diameter (Ø)	25mm
Quantity Per Pack (No.)	4
Thread	~
Over all Height	50mm
Attachment Type	Spigot
Nett Weight (kg)	1

HAFCO 50mm x M12 Multi-Purpose Riser/Stops (Spigot Type) - 4pc Pack SCA-5016P