

**METALMASTER WT16-2010N**



**2000 x 1000mm M16 Pro Series Welding Table**

**Plasma Nitriding Coating**



**METALMASTER 2000 x 1000mm M16 Pro Series Welding Table WT16-2010N**

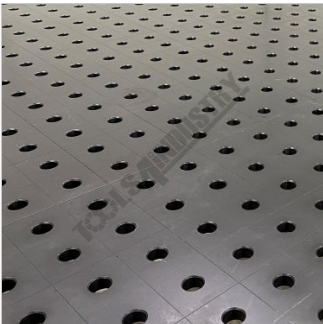

Plasma Nitriding Surface Finish



Perimeter Ruler Engraving

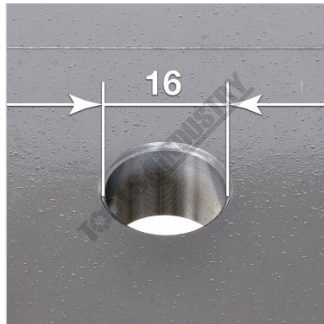

16mm Diameter Holes

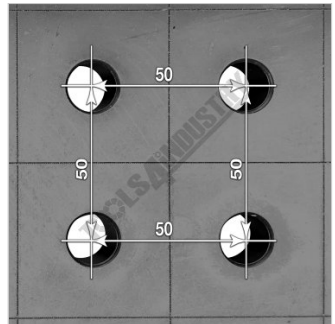

50 x 50mm Hole Centres Pattern

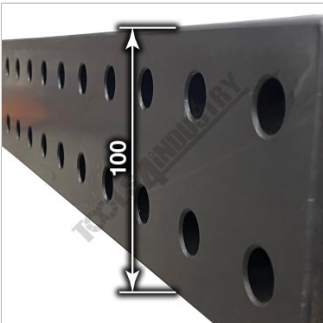

100mm sides



Strengthened by Welded Webbing

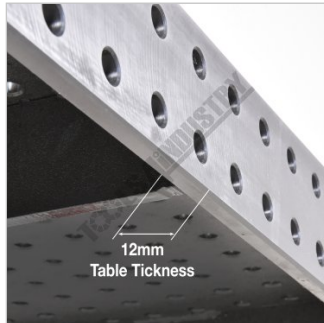

12mm Table Thickness



Adjustable Levelling Castor

**Description**

The Metalmaster M16 Pro Series welding tables features a welded & ribbed construction from heavy S355 plate steel, the frame is then CNC machined with the sides & top having a finished nominal thickness of 12mm. The CNC machining process is able to achieve a high flatness tolerance of +/- 0.1mm over 1m<sup>2</sup> to give you a smooth precision welding surface. During this CNC machining process, the Ø16mm holes are precision bored to ensure a hole distance tolerance of +/- 0.05mm & with an industry standard 50 x 50mm hole pattern it gives you a multitude of fixture holes to suit your application. Before removing the table from the machining centre, we engrave 50mm grid lines & perimeter ruler to give you millimetre precision helping you minimise mistakes while increasing productivity.

Our Pro Series tables have been designed with interlocking solid steel ribs & 100mm high sides to maintain rigidity with substantial load capacity for all medium sized fabrication projects. The hole spacing is an industry standard 50mm giving you almost endless possibilities for both welding and clamping applications. The table also comes complete with heavy powder coated tube steel legs complete with heavy duty caster wheels featuring integrated levelling feet ensuring a stable working surface.

This M16 Pro Series table come standard with a plasma nitriding coating which thermochemically case hardens the surface so not only making it harder but also making it spatter, wear & rust resistant.

Choose from our wide range of optional Pro Series clamping kits & fixturing accessories to add to your table giving you the ultimate welding & fixturing system so when you go into battle with your next fabrication project it's a knockout.

## METALMASTER 2000 x 1000mm M16 Pro Series Welding Table WT16-2010N

### Features

- Plasma nitriding surface finish for increased hardness, rust & spatter resistance
- Ø16mm Precision bored fixing holes at 50mm centres
- 50 x 50mm hole grid pattern offering a multitude of clamping options
- 50mm grid lines & perimeter ruler engraving
- Precision CNC machined to ensure flatness of +/- 0.1mm over 1m2
- Tabletop & sides manufactured from heavy S355 plate steel

### Includes

- 4pcs of heavy square steel legs c/w caster with integrated levelling feet

### Specifications

<b>ORDER CODE</b>	W07811
<b>MODEL</b>	WT16-2010N
<b>Table Top Finish (Type)</b>	Plasma Nitriding Coating
<b>Table Top Size (mm)</b>	2000 x 1000
<b>Table Height (mm)</b>	900
<b>Table Side Height (mm)</b>	100
<b>Top Plate Thickness (mm)</b>	12
<b>Grid Pattern (mm)</b>	50 x 50
<b>Table Hole Diameter (Ø)</b>	16
<b>Table Slots (mm)</b>	~
<b>Static Load Capacity (kg)</b>	2000
<b>Total W.L.L. (kg)</b>	~
<b>Number of Legs (No.)</b>	4
<b>Nett Weight (kg)</b>	315