

METALMASTER WT16-1208T



800 x 1200mm M16 Pro Series Welding Table Top with Pull-out Tray

1200 x 800 x 65mm (LxWxH)



METALMASTER 800 x 1200mm M16 Pro Series Welding Table Top with Pull-out Tray WT16-1208T

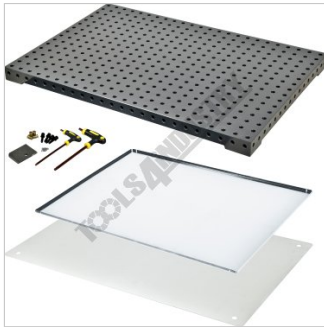

Included Components

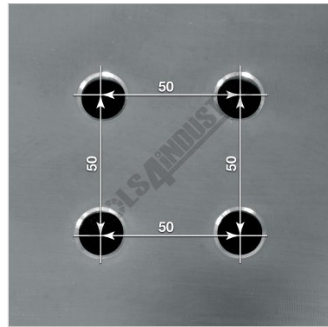

50 x 50mm Hole Centre Pattern

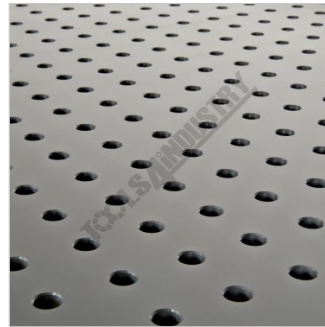
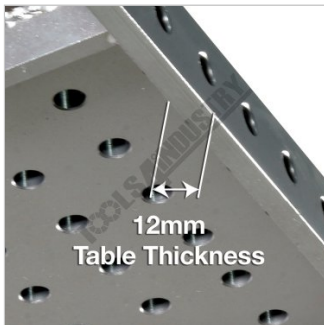

Table Manufactured from Heavy S355 Plate Steel



Ø16mm Diameter Holes



12mm Table Thickness

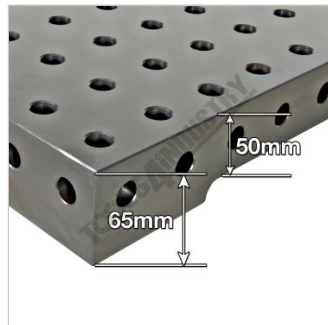

65mm High Ends with 50mm High Sides



Feet with 4 Mounting Holes



Strengthened by Welded Webbing

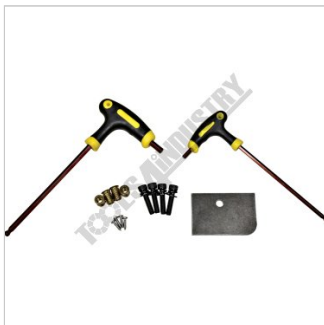

Included Tools, Jigs and Fixings

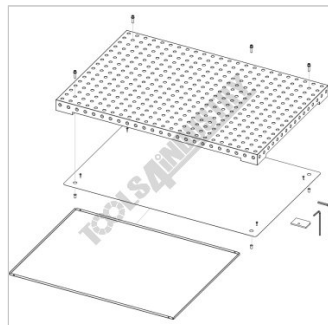

Assembly Drawing

Description

The WT16-1208T Metalmaster M16 Pro Series Welding Table Top with Pull-out Tray, has been designed to be paired with the TWS-622 Mobile Work Station to make the ultimate mobile welding solution.

The 800 x 1200mm Welding Table features a welded S355 steel frame, 12mm thickness, CNC-machined for precise flatness. Featuring Ø16mm holes with a 50 x 50mm hole pattern, it offers versatile clamping options for fixtures. Solid steel ribs and 50mm high sides ensure rigidity, while the plasma nitriding coating resists spatter, wear, and rust. It also includes a pull-out swarf tray for added convenience.

Suits the TWS-622 - Professional Series Mobile Work Station - sold separately

METALMASTER 800 x 1200mm M16 Pro Series Welding Table Top with Pull-out Tray WT16-1208T

Features

- 800 x 1200mm Tabletop with Pull-out Tray
- Tabletop is manufactured from heavy S355 plate steel finished nominal thickness of 12mm
- CNC machined to ensure flatness
- Plasma nitriding surface finish for increased hardness, rust & spatter resistance
- Ø16mm Precision bored fixing holes
- 50 x 50mm hole grid pattern offering a multitude of clamping options
- The kit includes a sheet steel cover for the benchtop, pull-out swarf tray, and hardware pack for mounting to benchtop

Includes

- 1 x WT16-1208T 800 x 1200mm Nitride Steel Welding Table Top
- 1 x 1150 x 740mm protective sheetmetal cover to suit the TWS-622 wood benchtop
- 1 x Pull-out Welding Splatter Tray
- 1 x Hardware Pack for mounting to benchtop.

Specifications

ORDER CODE	W07806
MODEL	WT16-1208T
Table Top Finish (Type)	Plasma Nitriding Coating
Table Top Size (mm)	800 x 1200
Table Height (mm)	65
Table Side Height (mm)	50 / 65
Top Plate Thickness (mm)	12
Grid Pattern (mm)	50 x 50
Table Hole Diameter (Ø)	16
Table Slots (mm)	~
Static Load Capacity (kg)	~
Total W.L.L. (kg)	~
Number of Legs (No.)	~
Nett Weight (kg)	115