

RECORD POWER BS350S



Wood Band Saw



RECORD POWER Wood Band Saw BS350S

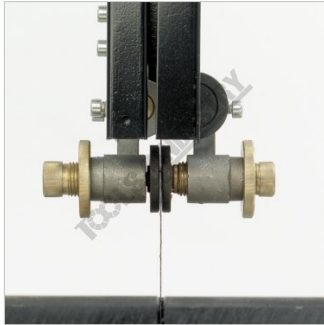

Accurate and Easy to Use
Blade Guides



Cam Action Tensioner

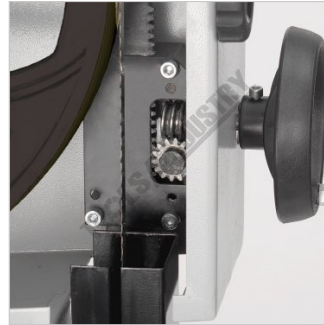

Toolpost Support



Trunnion



Industrial Style Fence



Large Cast Iron Table

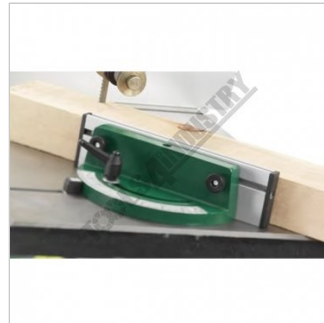

Mitre Fence



Cast Iron Blade Wheels

Description

Record Power BS350S Wood Band Saw

An ideal workhorse for the busy workshop where power and generous capacity are required but budget and space do not allow a bigger machine.

This features an open legstand, often requested by our users as it provides greater stability and can be used with an optional pedal style wheelkit. A basic wheelkit is provided as standard. The bandwheels are cast iron and dynamically balanced with precision ground, crowned rubber tyres usually only found on much more expensive industrial machines – the flywheel effect of the cast iron wheels improves cutting performance and speeds.

Our tables are some of the largest in their category and a one piece cast double trunnion has been designed to provide even greater support and rigidity.

The rip fence is the strongest and most industrial in its category with a chromed fence and the mount machined from a single piece of cast iron. The extrusion itself is a heavy section to provide rigidity and accuracy.

Features

- Cast Iron Band Wheels - These are fitted with precision ground rubber tyres to provide a flywheel effect for smooth cutting. Simple tension indicator also shown.
- Industrial Startrite Style Fence - This high quality fence features a heavy extrusion mounted on a cast iron base, which moves along a solid steel bar. This provides exceptional strength and accuracy and is easily locked with the brass screw and handle.
- Large Cast Iron Table - This provides a strong and steady work area to support large work-pieces. Finely ground finish enables effortless movement of the timber.
- Mitre Fence Included - A solid and easy to use mitre fence is included with this machine.
- Cam Action Tensioner - With the flick of a handle the tension is released on the blade enabling quick easy changing, but more importantly, when reset, the previous tension is automatically applied to the new blade. This makes blade changing a much simpler task and allows tension to be taken off the blade when not in use.

RECORD POWER Wood Band Saw BS350S

- Toolpost - The toolpost features jacking screws and rack and pinion rise and fall for easy adjustment.
- Micro switches - Are fitted top and bottom for added safety, cutting power to the machine when the doors are opened.
- Motor - Quiet and powerful 1-1/2hp output induction motor will handle a wide variety of projects with ease.
- Easy Open Door Handles - Make access inside the cabinet much easier. Micro-switch protected but always disconnect power supply before making any adjustments.
- Steel Stand - With splayed legs to provide better stability than some cabinet stands.
- Wheel-kit - A basic wheel kit is provided as standard which is suitable for occasional use.
- Accurate and Easy to Use Blade Guides - Blade guides need accurately setting if they are to be of any use – so easy access and adjustment are a must. Our guides, similar to those found on industrial machines, give good quality adjustment with minimal need for tools.
- Substantial Trunnion - Solid double trunnion table mount for rigid table support featuring one handed rack and pinion table tilt for ease of use and accuracy. Mounted on top of band wheel box with jacking screws for easy adjustment.
- Band saw Master-class DVD Included - Presented by Alan Holtham, this indispensable DVD gives a thorough and comprehensive introduction to band saw use, setup, maintenance and blade choice.
- Table Height from Floor: 998mm
- Blade Speeds: 820 & 380 M/minute
- Extraction Port Diameter: Ø100mm
- Size: L780 x W880 x H1795mm

Includes

- Stand
- Mitre guide
- Heavy Duty Rip fence

Specifications

| | |
|-------------------------------------|---------------------|
| ORDER CODE | R822 |
| MODEL | BS350S |
| Wheel Diameter (Ø) (mm) | 350 |
| Throat Capacity (mm) | 340 |
| Height Capacity (mm) | 230 |
| Table Size (mm) | 548 x 500 |
| Frame Type | Steel |
| Motor Power (kW / hp) | 1.125 / 1.5 |
| Voltage / Amperage (V / amp) | 240 / 10 |
| Blade Code (Suits) | R822A, R822B, R822F |
| Blade Size (L x W x T) (mm) | 2628 x 16 x 0.65 |
| Floor Space (W x D x H) (mm) | 1000 x 800 x 1810 |
| Nett Weight (kg) | 103 |