

# RECORD POWER BS300E



## Wood Band Saw



## RECORD POWER Wood Band Saw BS300E



Large 190mm Depth of Cut



Industrial Startrite Style Fence



Large Cast Iron Table



Mitre Fence

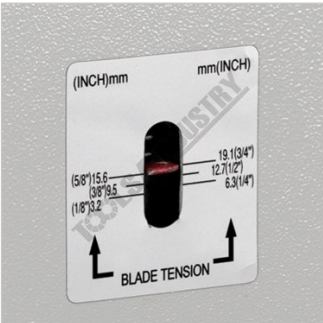

Blade Tension Indicator



Cast Iron Band Wheels



Doors Open

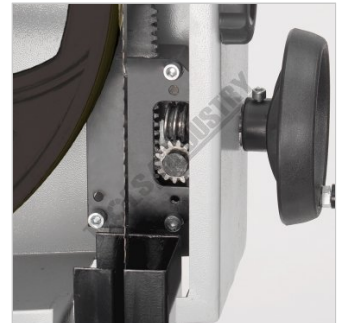

Toolpost Support



Trunnion

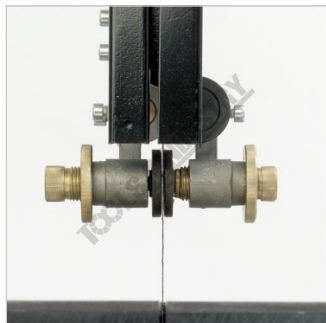

Accurate and Easy to Use Blade Guides



Tracking System



Shown with Optional BS300 A Wheelkit

### Description

The Record Power BS300E is a great all rounder perfectly specified for the medium sized workshop where a range of duties will be required.

Featuring a solid fence, vital for accurate ripping, which has a heavy extrusion mounted on a cast iron base and fixed to a solid steel bar for maximum rigidity and support. This is based on an industrial Startrite design and much more solid than other fences at this level. The machine also features a solid double trunnion fence mount to provide rigid table support and one-handed table tilt on a smooth rack and pinion. Adding to the structural integrity of the BS300E are the cast iron bandwheels which are fitted with precision ground rubber tyres to provide a flywheel effect for smooth cutting. A solid blade tension indicator is fitted to the rear of the machine to allow for easy setup.

Microswitches are fitted top and bottom for added safety, cutting power to the machine if the doors are opened. The BS300E is also supplied with a basic wheelkit as standard.

## RECORD POWER Wood Band Saw BS300E

### Features

- Blade Tension Indicator - The blade tension guide is situated on the rear of the machine.
- Industrial Startrite Style Fence - This high quality fence features a heavy extrusion mounted on a cast iron base, which moves along a solid steel bar. This provides exceptional strength and accuracy and is easily locked with the brass screw and handle.
- Large Cast Iron Table - This provides a strong and steady work area to support large workpieces. Finely ground finish enables effortless movement of the timber.
- Cast Iron Band Wheels - These are dynamically balanced and provide a flywheel effect for improved cutting performance. Rubber tyres are precision ground for easy blade fitting and smooth drive.
- Tracking System - Easy blade tracking allows accurate positioning of blade.
- Toolpost - The toolpost features jacking screws and rack and pinion rise and fall for easy adjustment.
- Accurate and Easy to Use Blade Guides - Blade guides need accurately setting if they are to be of any use – so easy access and adjustment are a must. Our guides, similar to those found on industrial machines, give good quality adjustment with minimal need for tools.
- Mitre Fence - A solid and easy to use mitre fence is included with this machine.
- Microswitches - Are fitted top and bottom for added safety. Cuts power to machine when doors are opened.
- Motor - Quiet and powerful 1hp output induction motor will handle a wide variety of projects with ease.
- Steel Stand - With splayed legs to provide better stability than some cabinet stands.
- Wheelkit - A basic wheelkit is provided as standard which is suitable for occasional use. For those wishing to move the machine on a regular basis we recommend the BS300A Pedal Wheelkit.
- Substantial Trunnion - Solid double trunnion table mount for rigid table support featuring one handed rack and pinion table tilt for ease of use and accuracy. Mounted on top of band wheel box with jacking screws for easy adjustment.
- Bandsaw Masterclass DVD Included - Presented by Alan Holtham, this indispensable DVD gives a thorough and comprehensive introduction to bandsaw use, setup, maintenance and blade choice.
- Table Height from Floor: 990mm
- Blade Speeds: 820 & 380 M/minute
- Extraction Port Diameter: Ø100mm
- Size: L680 x W880 x H1690mm

### Includes

- Stand
- Mitre guide
- Heavy Duty Rip fence

### Specifications

<b>ORDER CODE</b>	R821
<b>MODEL</b>	BS300E
<b>Wheel Diameter (Ø) (mm)</b>	~
<b>Throat Capacity (mm)</b>	305
<b>Height Capacity (mm)</b>	190
<b>Table Size (mm)</b>	480 x 400
<b>Frame Type</b>	Steel
<b>Motor Power (kW / hp)</b>	0.75 / 1
<b>Voltage / Amperage (V / amp)</b>	240 / 10
<b>Blade Code (Suits)</b>	W420A, W420B, W420F
<b>Blade Size (L x W x T) (mm)</b>	2368 x 12.5 x 0.65
<b>Floor Space (W x D x H) (mm)</b>	~
<b>Nett Weight (kg)</b>	80

**RECORD POWER Wood Band Saw BS300E**