

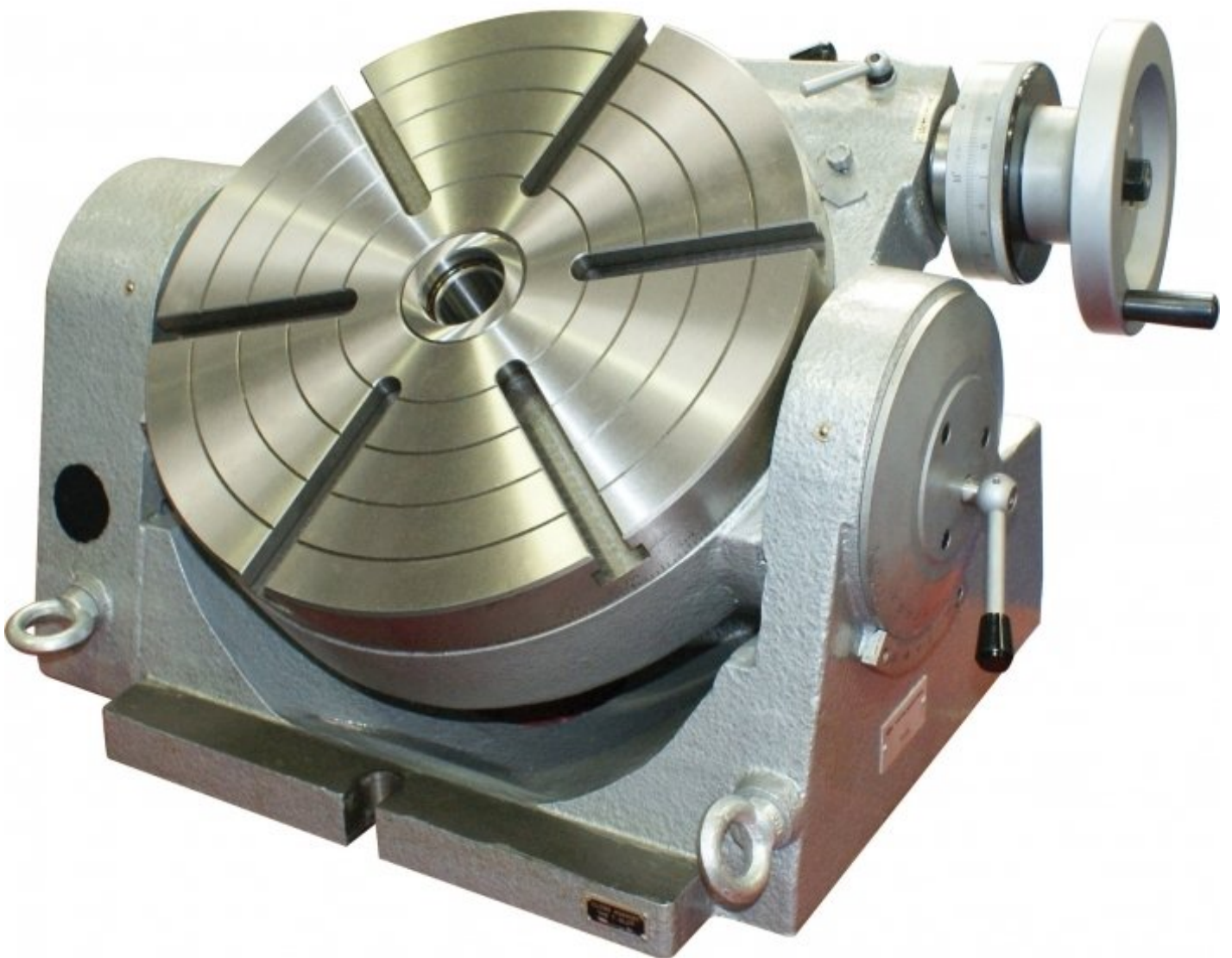

TOOLMASTER TRT-12

Tilting Rotary Table

Ø320mm



TOOLMASTER Tilting Rotary Table TRT-12

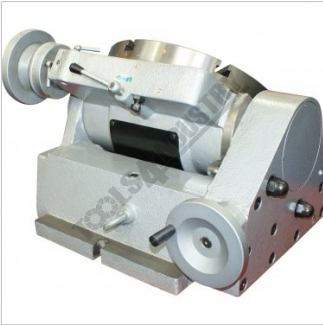

Rear View

Features

- An accurately designed rotary table for milling, boring and other machining operations
- The table allows for indexing, and other operations to be carried out rapidly with precision
- Low profile design minimises machine capacity losses without sacrificing work load capacity
- Tilting range from 0 - 90 degrees from the horizontal to vertical position and locked
- T-slots are machine to accept standard tee nuts
- One spindle rotation of the handle is equal to 3 degrees
- Accuracy of the tilting operation is 2 minutes
- 10 second vernier scale on table
- Table dial graduations 1 minute
- Worm ratio is 90:1
- Includes dividing plates

Specifications

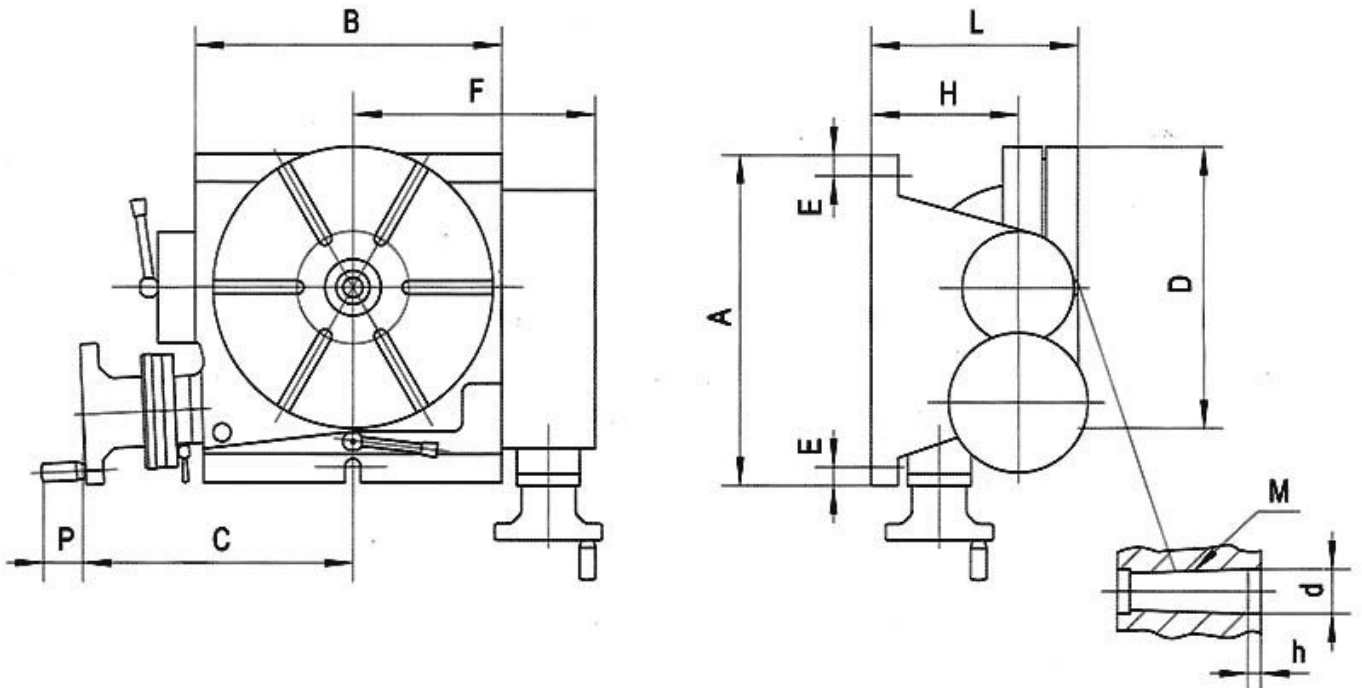

TOOLMASTER Tilting Rotary Table TRT-12

ORDER CODE

TOOLMASTER Tilting Rotary Table TRT-12

R028

MODEL	TRT-12
Size (mm)	320
A (mm)	380
B (mm)	322
C (mm)	252
D (mm)	Ø320
E (mm)	16
F (mm)	241
H (mm)	175
L (mm)	255
M (MT)	MT4
P (mm)	40
d (lowercase) (mm)	Ø40
h (lowercase) (mm)	10
T-Slot Size (mm)	14
Worm Ratio	90:1