

**SUNRISE PDS-40**



**Ø11-40mm Round Punch & Dies Set**

**Hi -Grade Tool Steel Imported From Japan**



**SUNRISE Ø11-40mm Round Punch & Dies Set PDS-40****Description**

Punch and Dies are Manufactured by Sunrise in Taiwan using Hi -Grade Tool Steel imported from Japan. The manufacturing process involves machining via hi tech CNC machines lathes & mills, vacuum heat treatment with multiple tempering at high temperatures before a final quality inspection/testing process all of which ensures an accurate, precise, durable & stable product.

**Features**

- Set includes punch & dies:
- 11mm Punch & 11.7mm Die
- 13mm Punch & 13.7mm Die
- 19mm Punch & 19.7mm Die
- 24mm Punch & 25.2mm Die
- 25mm Punch & 26.2mm Die
- 28mm Punch & 29.2mm Die
- 30mm Punch & 31.2mm Die
- 32mm Punch & 33.2mm Die
- 38mm Punch & 39.2mm Die
- 40mm Punch & 41.2mm Die

**Specifications**

**SUNRISE Ø11-40mm Round Punch & Dies Set PDS-40**

**Punches**  
11, 13, 19, 24, 25, 28, 30

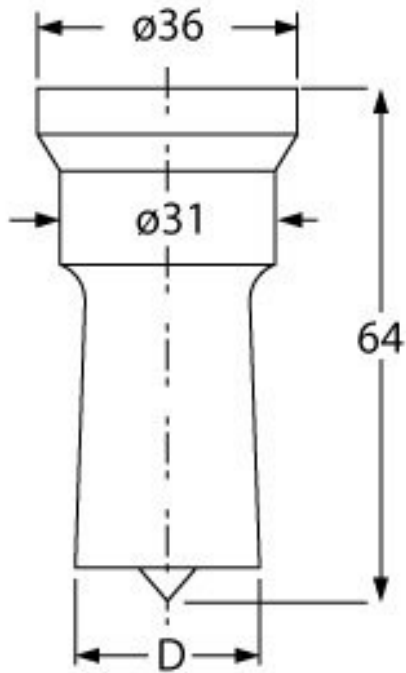

**Punches**  
32, 38, 40

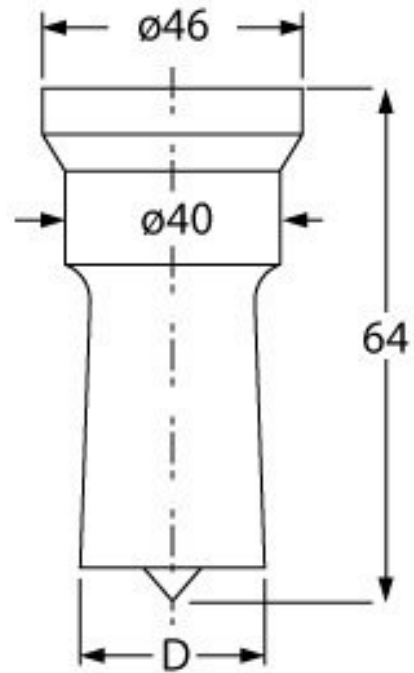

**Dies 11.7 ~ 31.2**

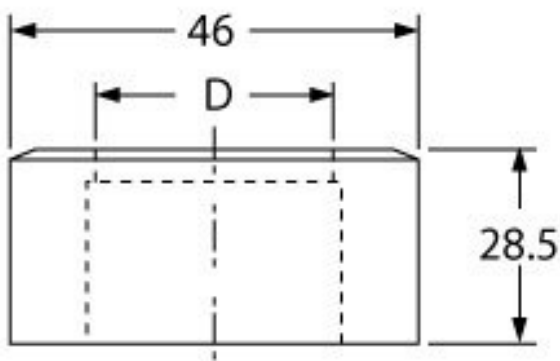

**Dies 33.2 ~ 41.2**

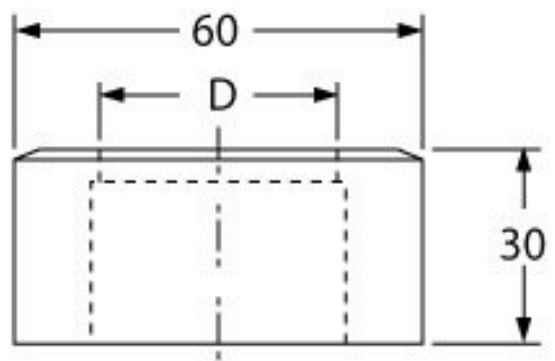

**SUNRISE Ø11-40mm Round Punch & Dies Set PDS-40**

**ORDER CODE**

**SUNRISE Ø11-40mm Round Punch & Dies Set PDS-40**

P166

<b>MODEL</b>	~
<b>Type</b>	Punch & Die Set
<b>Punch Diameter (D) (mm)</b>	Ø11 - 40
<b>Die Diameter (D) (mm)</b>	Ø11.7 - 41.2
<b>Pack Quantity (No.)</b>	10