

**TOOLMASTER TPS-20**

**Touch Point Sensor**

**156mm Long**

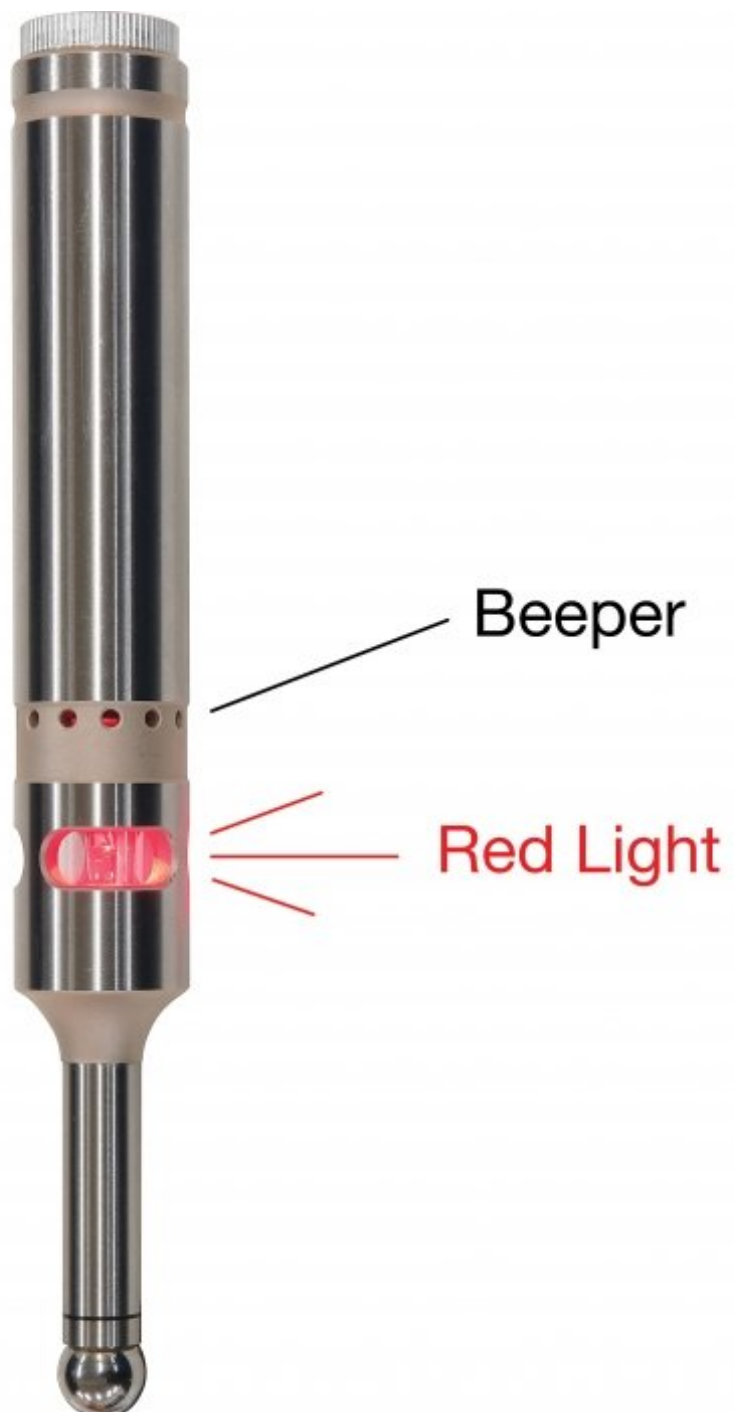

## TOOLMASTER Touch Point Sensor TPS-20



Action shot



Side View



Battery Operated



Front View



Rear View



Red Light Illuminates & Audio Beep Sound Alerts for Deeper Holes



Spring Loaded Ø10mm Ball



Spring Loaded Ø10mm Ball Shown

### Description

A valuable setting up tool for all machine shops and is excellent for quickly locating work edges accurately on milling machines alike.

### Features

- Accuracy within 0.005mm
- Bright red LED light illuminates in conjunction with a loud audible beep sound when prob touches conductive work piece
- Spring-loaded safety ball end that returns precisely back to the position when ball breaks away from ball seat
- Ø10mm hardened & ground ball end probe for continuous accuracy
- No need to rotate while measuring or finding edges

### Includes

- 1 x A23 battery

**TOOLMASTER Touch Point Sensor TPS-20**

**Specifications**

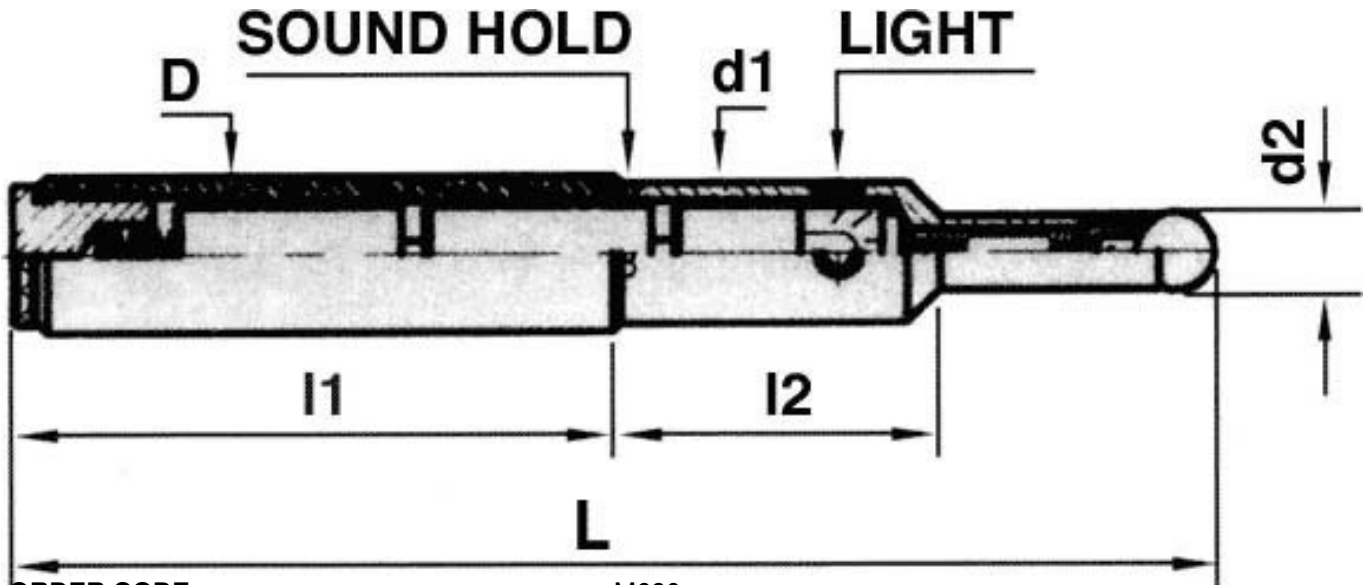

ORDER CODE	M690
MODEL	TPS-20
Type	Touch Point Sensor
Accuracy (mm)	0.005
Shank Diameter	~
Tip Diameter (mm)	~
Length without clamping shank (mm)	~
Overall Length	~
D (mm)	20
d2 (mm)	10
L (mm)	156
L1 (mm)	76
L2 (mm)	32
Battery	A23
Nett Weight (kg)	0.3kg