

HAFCO HMA-4100

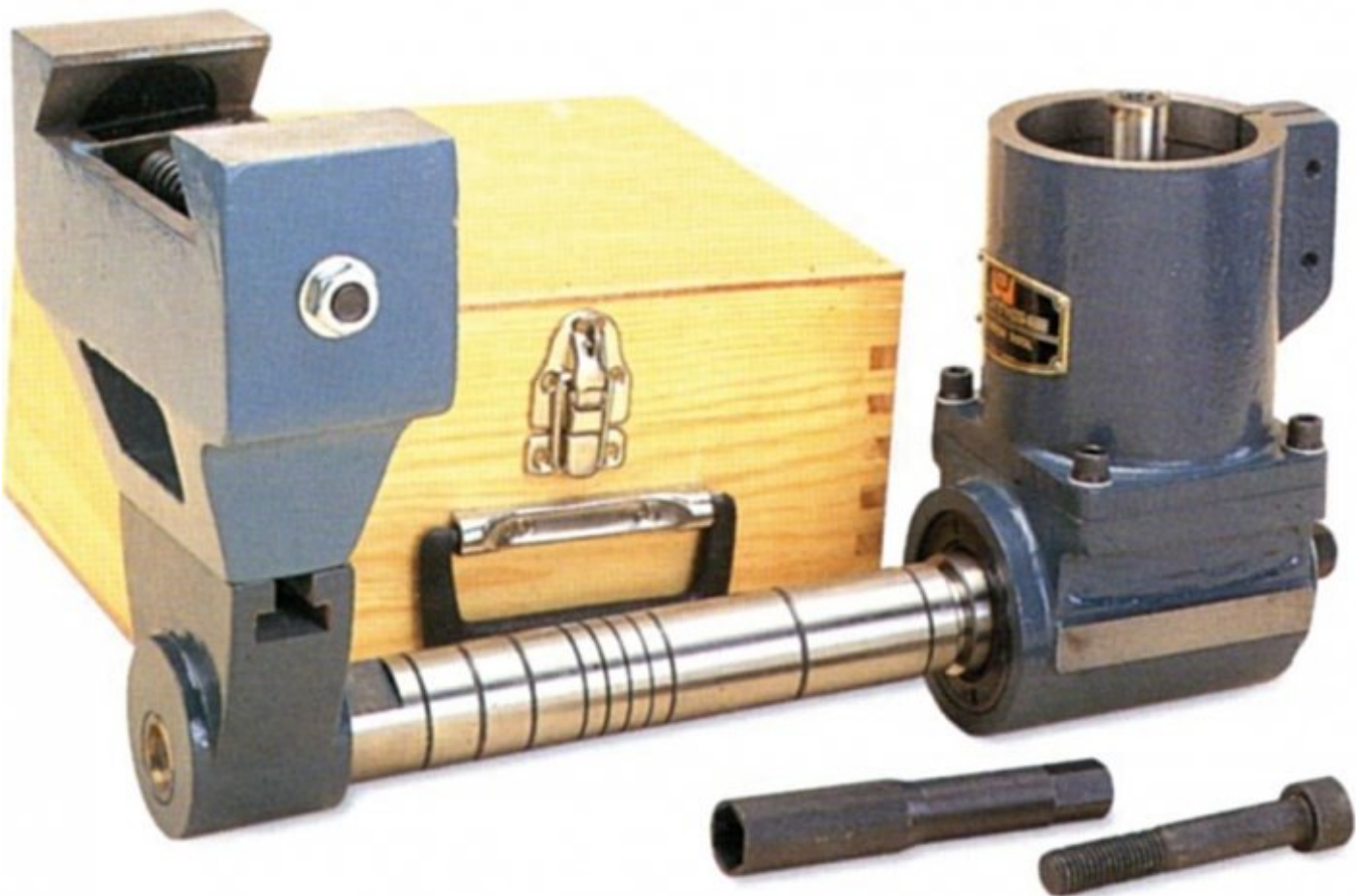

NT40 Horizontal Milling Attachment

Suits Ø100mm Quill



HAFCO NT40 Horizontal Milling Attachment HMA-4100

Description

Used on vertical milling machine where horizontal work is required.
Designed to simplify right angle work without the need for special tooling or complex fixtures.

Note! If using with an air powered drawbar the drive motor of the drawbar needs to be removed as the quill is lowered so that the horizontal attachment can be secured. As the quill is lowered the air drawbar is dis-engaged and cannot be used. For this application use a standard drawbar.

Features

- Arbor support suits dovetail widths of 140-170mm
- Supplied in deluxe wooden case
- Arbor $\varnothing 1"$ x 12" in length

Specifications

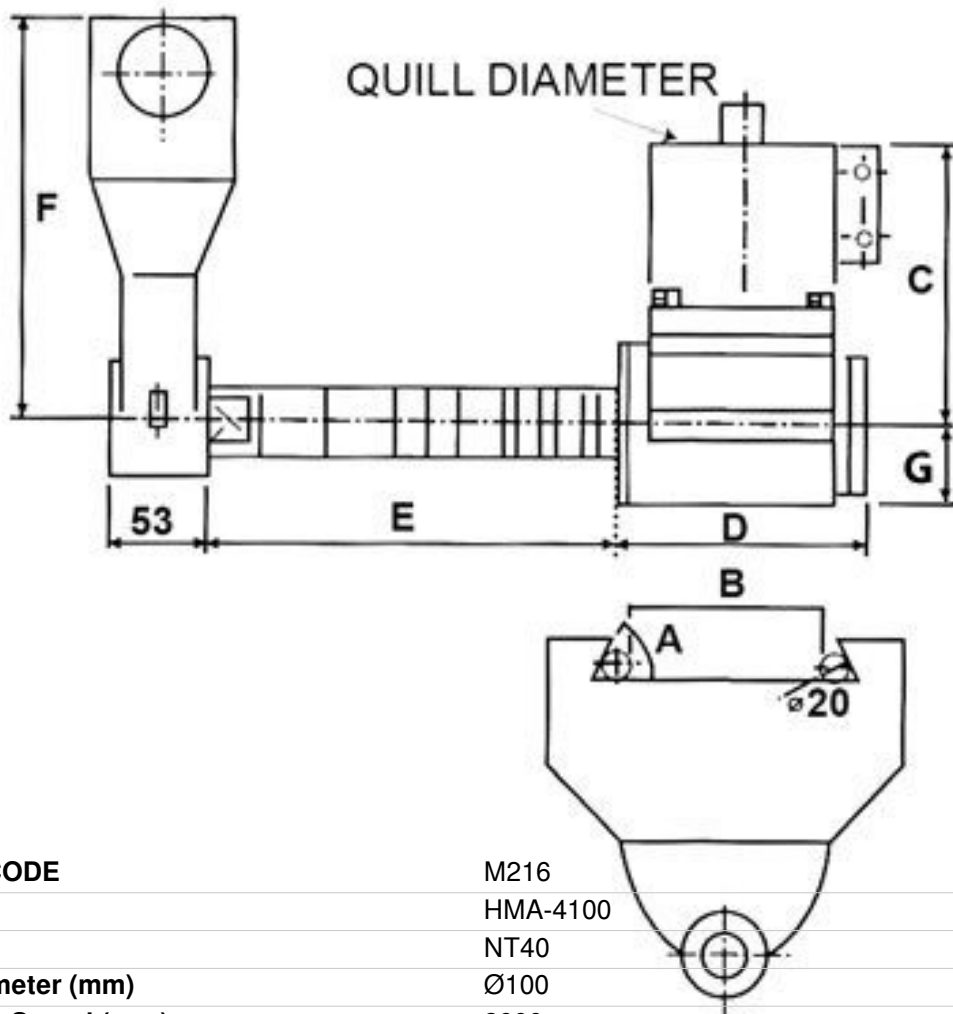

ORDER CODE	M216
MODEL	HMA-4100
Taper	NT40
Quill Diameter (mm)	$\varnothing 100$
Maximum Speed (rpm)	2000
A (deg)	50°
B (mm)	140 - 170

HAFCO NT40 Horizontal Milling Attachment HMA-4100

C (mm)	181
D (mm)	181
E (mm)	270
F (mm)	230
G (mm)	45
Nett Weight (kg)	33