

**HAFCO-METALMASTER HMA-386**

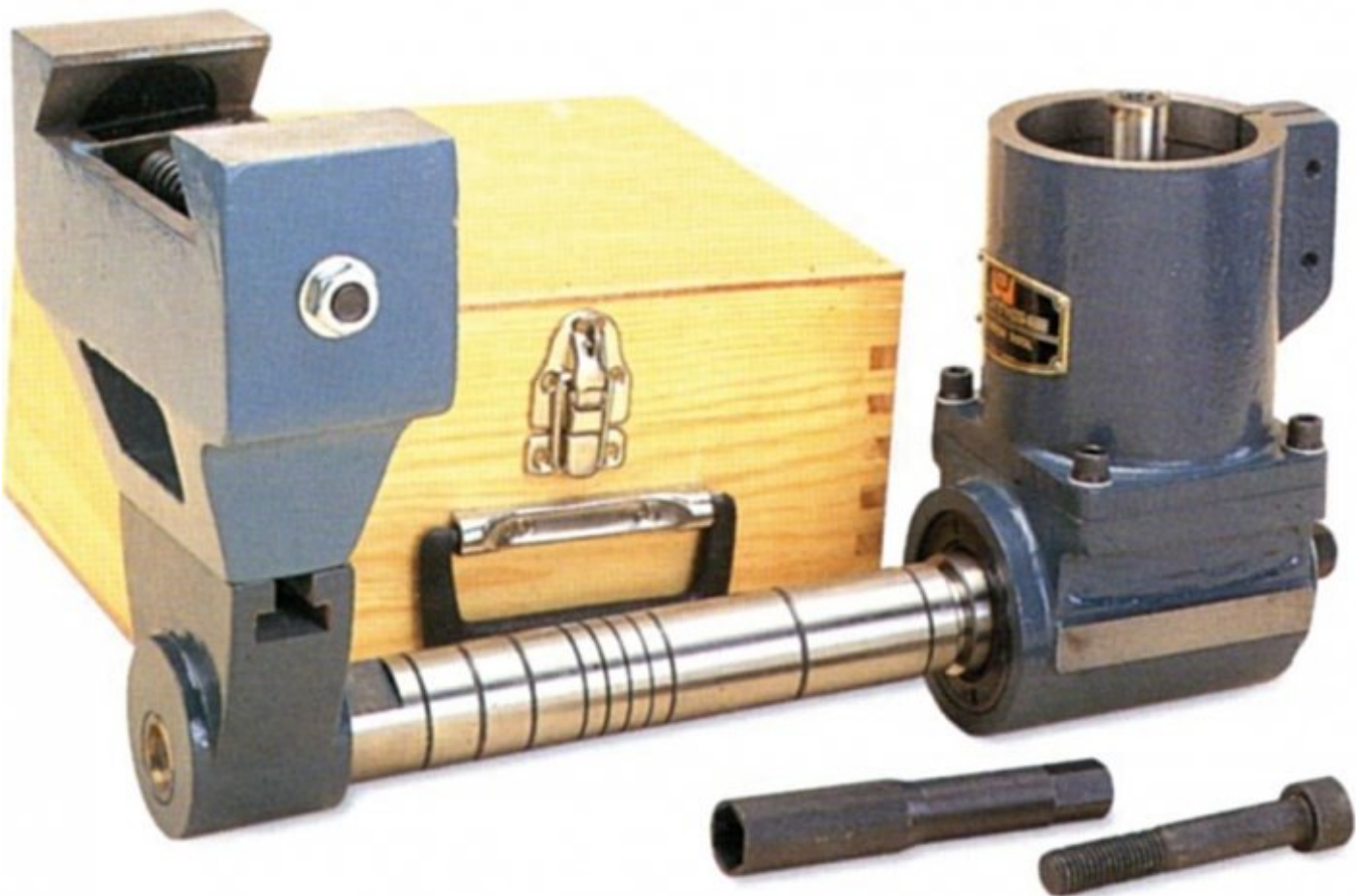

**NT30 Horizontal Milling Attachment**

**Suits Ø86mm Quill**



## HAFCO-METALMASTER NT30 Horizontal Milling Attachment HMA-386

### Description

Manufactured in Taiwan

Used on vertical milling machine where horizontal work is required.  
Designed to simplify right angle work without the need for special tooling or complex fixtures.

Note! If using with an air powered drawbar the drive motor of the drawbar needs to be removed as the quill is lowered so that the horizontal attachment can be secured. As the quill is lowered the air drawbar is dis-engaged and cannot be used. For this application use a standard drawbar.

### Features

- Arbor support suits dovetail widths of 140-170mm
- Supplied in deluxe wooden case
- Arbor  $\varnothing 1" \times 12"$  in length

### Specifications

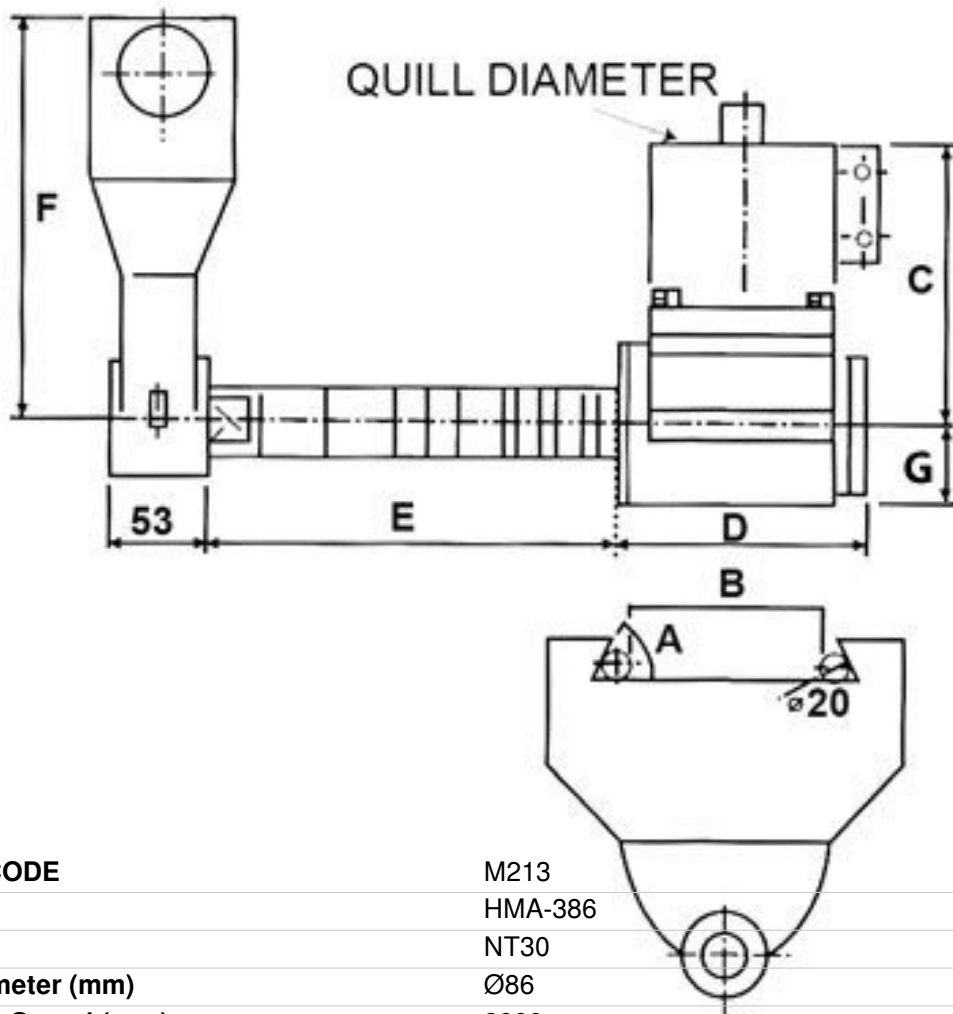

<b>ORDER CODE</b>	M213
<b>MODEL</b>	HMA-386
<b>Taper</b>	NT30
<b>Quill Diameter (mm)</b>	$\varnothing 86$
<b>Maximum Speed (rpm)</b>	2000
<b>A (deg)</b>	$50^\circ$

## HAFCO-METALMASTER NT30 Horizontal Milling Attachment HMA-386

<b>B (mm)</b>	140 - 170
<b>C (mm)</b>	175
<b>D (mm)</b>	160
<b>E (mm)</b>	270
<b>F (mm)</b>	230
<b>G (mm)</b>	45
<b>Nett Weight (kg)</b>	30