

TOOLMASTER



R8-MT2-30 Milling Adaptor



TOOLMASTER R8-MT2-30 Milling Adaptor

Description

Precision ground and hardened.
Morse taper adaptors are used to adapt a Morse taper tool or cutter to any spindle taper

Specifications

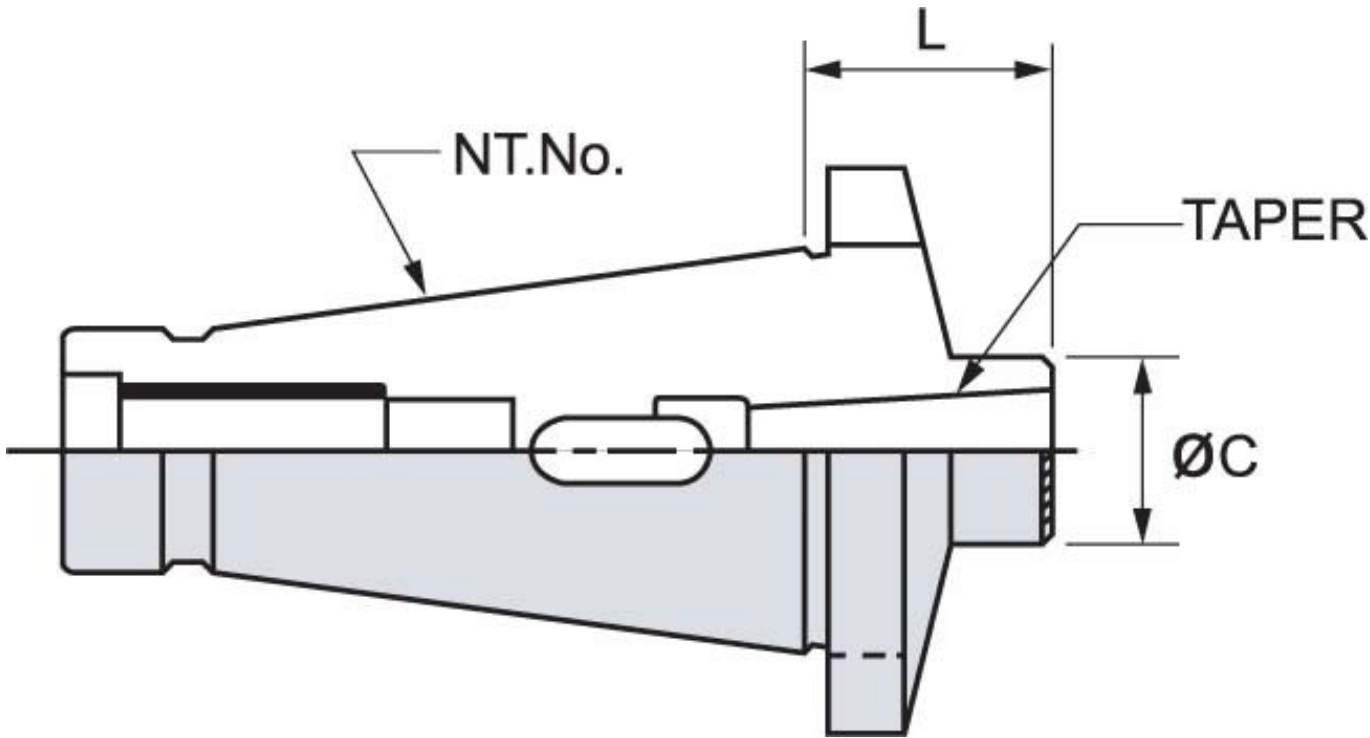

ORDER CODE	M169
MODEL	R8-MT2-30
Outer Taper	R8
Inside Taper	MT2
Drawbar Thread (mm / inch)	7/16"
L (mm)	30
C (mm)	32
Nett Weight (kg)	0.40