

TOOLMASTER

NT30-MT3-65 Milling Adaptor



TOOLMASTER NT30-MT3-65 Milling Adaptor

Description

Precision ground and hardened.
Morse taper adaptors are used to adapt a Morse taper tool or cutter to any spindle taper

Specifications

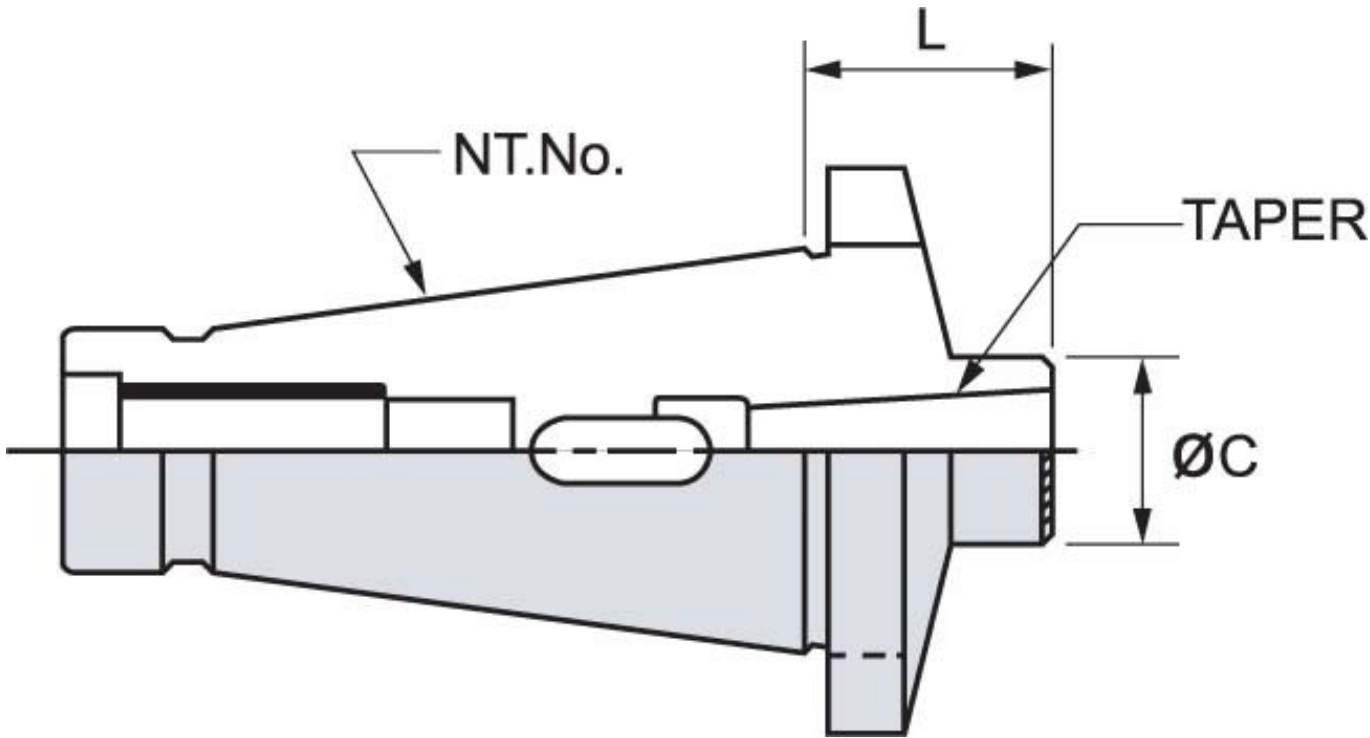

ORDER CODE	M166
MODEL	NT30-MT3-65
Outer Taper	NT30
Inside Taper	MT3
Drawbar Thread (mm / inch)	12mm
L (mm)	65
C (mm)	40
Nett Weight (kg)	0.90