

TOOLMASTER S25T-CTFPR-16

Right Hand Boring Bar

Ø25mm



TOOLMASTER Right Hand Boring Bar S25T-CTFPR-16



Full View



Side View



Locking Tool

Description

NOTE: Inserts NOT included with tool holders.

Use insert TPMPR 160308 (L063)

Features

- Positive rake turning tool holder with 90° approach angle
- Suitable for heavy duty cutting

Specifications

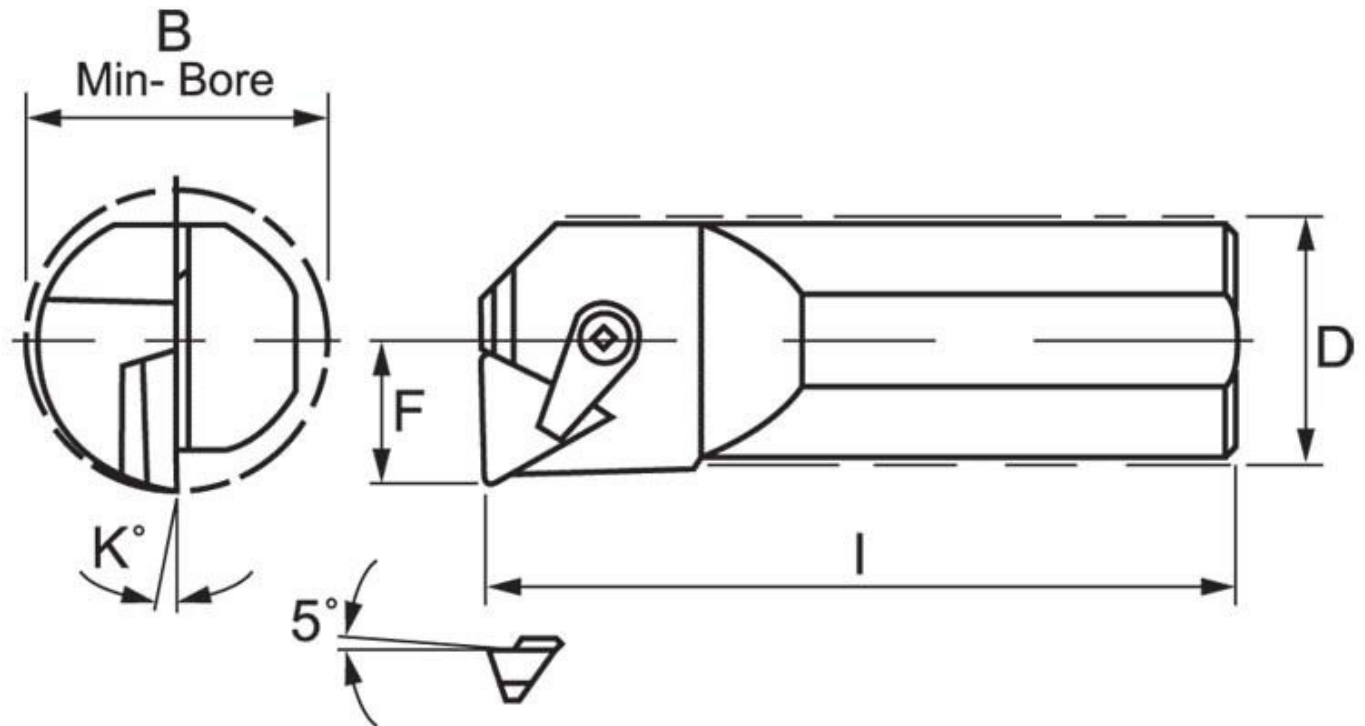

ORDER CODE

TOOLMASTER Right Hand Boring Bar S25T-CTFPR-16

TOOLMASTER Right Hand Boring Bar S25T-CTFPR-16

Part Number - Style	~
Size (mm)	25
Hand Type	RIGHT
B = Minimum Bore (mm)	34
D (mm)	25
F (mm)	17
L (mm)	300
K (deg)	3°
Minimum Bore (mm)	29.5