

TOOLMASTER S16Q-CTFPR-11

Right Hand Boring Bar

Ø16mm



TOOLMASTER Right Hand Boring Bar S16Q-CTFPR-11

Description

NOTE: Inserts NOT included with tool holders.

Use insert TPMPR 110304 (L061)

Features

- Positive rake turning tool holder with 90° approach angle
- Suitable for heavy duty cutting

Specifications

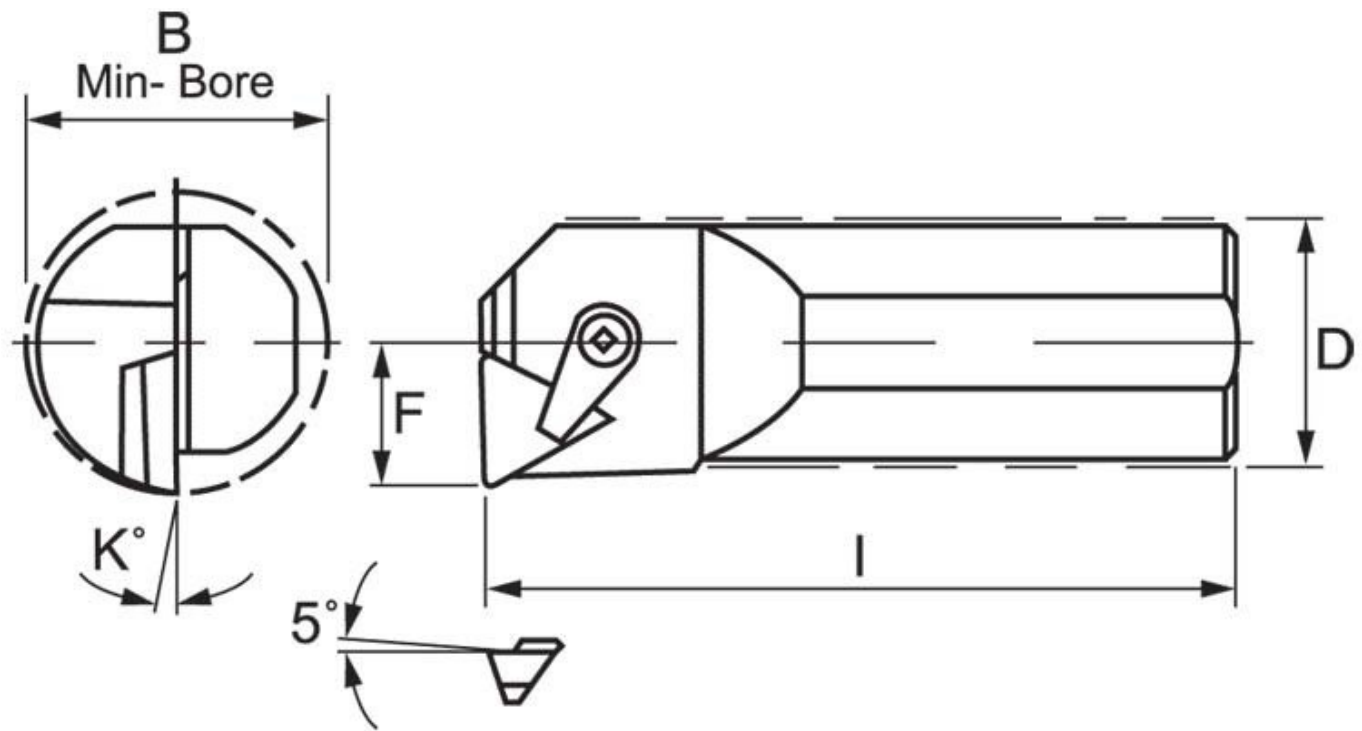

ORDER CODE	L422
Part Number - Style	~
Size (mm)	16
Hand Type	RIGHT
B = Minimum Bore (mm)	22
D (mm)	16
F (mm)	11
L (mm)	200
K (deg)	4°
Minimum Bore (mm)	19