

**TOOLMASTER Model A**

**Quick Change Toolpost**

**168mm Lathe Centre Height**



## TOOLMASTER Quick Change Toolpost Model A

### Description

Manufactured from carbonized and hardened steel.  
 Italian design style.

### Features

- All bearing surfaces are precision ground to ensure rigidity
- Handy lathe accessory for tool rooms and general engineering shops
- Ease of operation cuts set-up time by 90%
- No shims are required to adjust tools to correct centre height
- Easily fitted to most centre lathes
- Please Note: Some machining required to suit your lathe

### Includes

- 5 x Square Tool Holders - for 20mm tools
- 1 x Vee Tool Holders - for boring bars

### Specifications

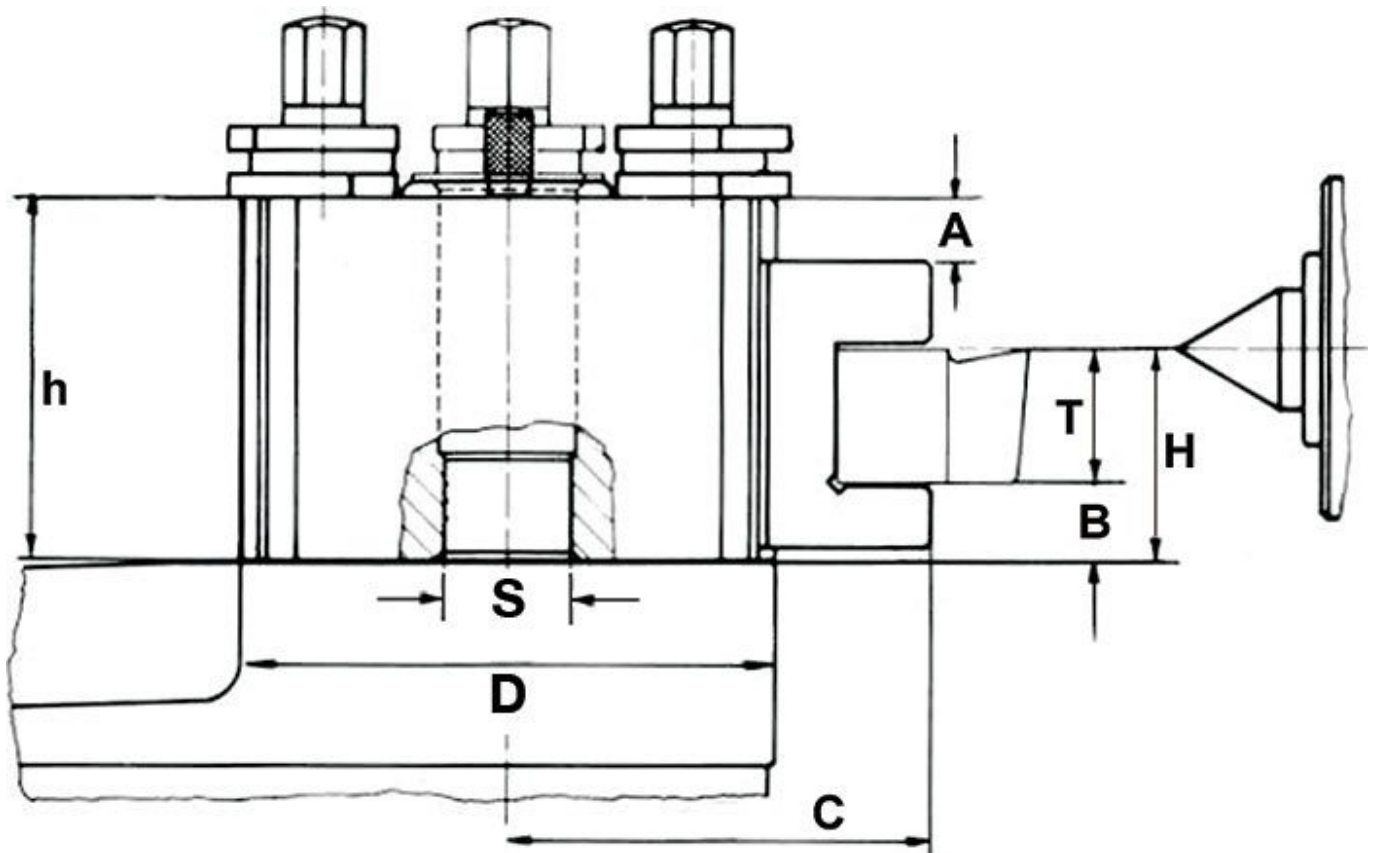

ORDER CODE	L293
MODEL	A
Lathe Centre Height (mm)	168

**TOOLMASTER Quick Change Toolpost Model A**

<b>Lathe Swing (mm)</b>	336
<b>A (mm)</b>	10
<b>B (mm)</b>	12
<b>C (mm)</b>	75
<b>D (mm)</b>	100
<b>E (mm)</b>	~
<b>H (mm)</b>	32 - 42
<b>h (mm)</b>	60
<b>S (mm)</b>	24
<b>T (mm)</b>	20
<b>Y (mm)</b>	~
<b>Number of Sides (No.)</b>	3
<b>Number of Holders (No.)</b>	6
<b>Nett Weight (kg)</b>	11.4