

KYOCERA TNMG 160408-6G

KYOCERA
JAPANESE CARBIDE

Carbide Inserts - Turning

Grade V122



KYOCERA Carbide Inserts - Turning TNMG 160408-6G



Tip

Description

INDEXABLE INSERTS
VANDURIT CARBIDE is manufactured in Italy

Features

- Grade V122 - General purpose for finishing and medium roughing on steels, stainless steels and cast iron (Coated)
- 10 Inserts Per Pack

Specifications

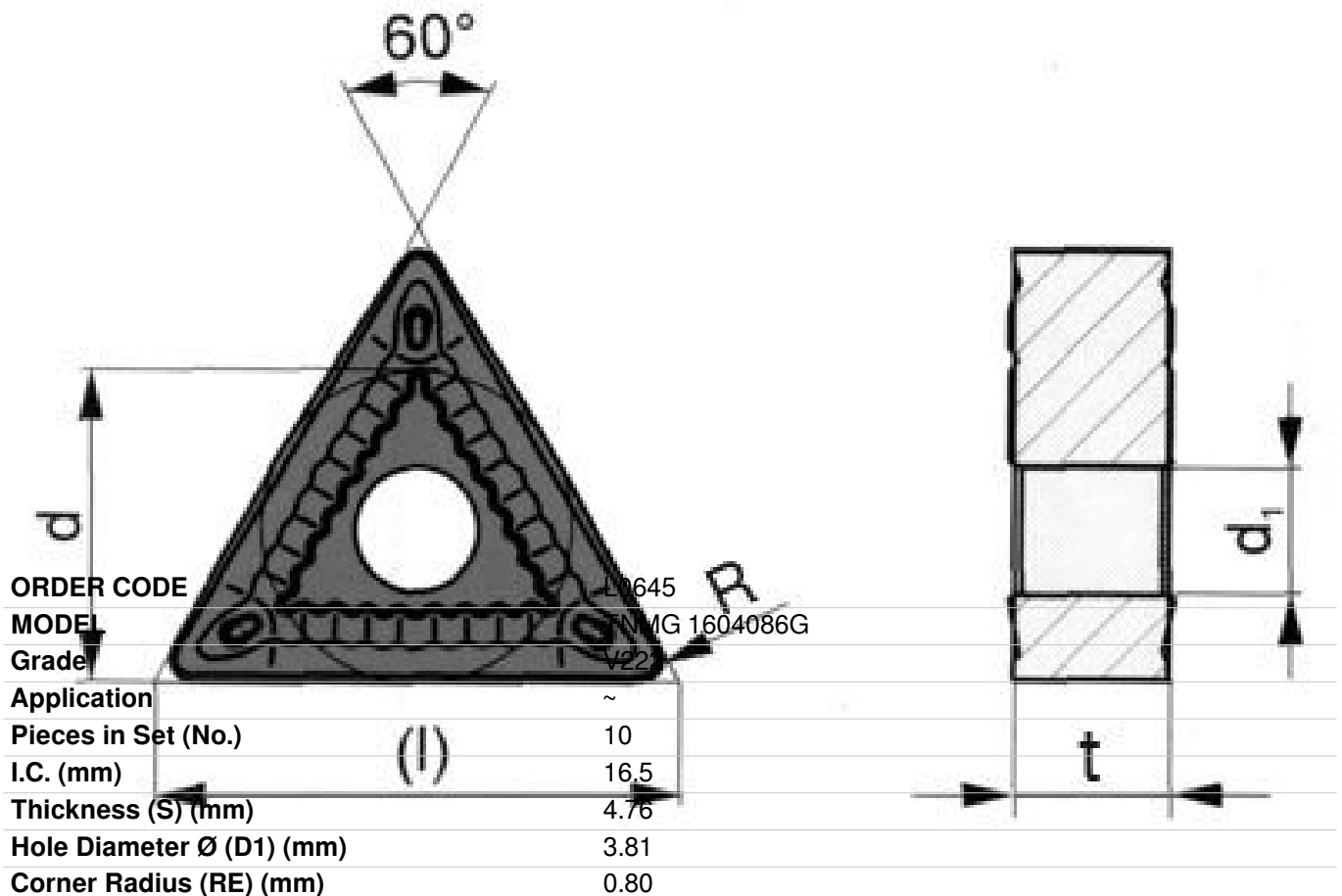

KYOCERA Carbide Inserts - Turning TNMG 160408-6G

Relief Angle (Deg)	~
d (mm)	9.525
Insert shape	~
Use Classification	~
Clearance Angle	~