

TOOLMASTER PCLNR-2525-K12

Right Hand Turning Tool Holder

25mm Tool Height



TOOLMASTER Right Hand Turning Tool Holder PCLNR-2525-K12



Tool Holder



Side View



Top View

Description

Quality Tipped Tool Holders ISO Standard to suit Tungsten Carbide Indexable Insert Tips.

NOTE: Inserts not included with tool holders

Use insert CNMG 120408 (L0602)

Features

- Negative rake turning tool holder with 95° approach angle
- Suitable for rapid metal removal
- Right hand tool holder suitable for turning towards the chuck

Specifications

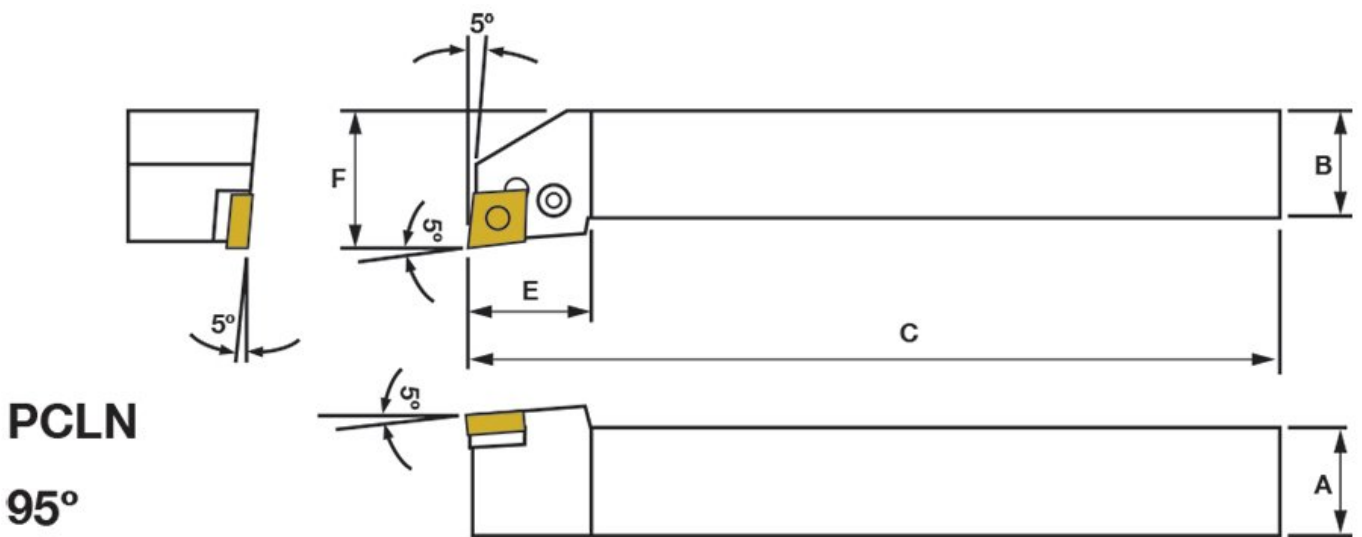

TOOLMASTER Right Hand Turning Tool Holder PCLNR-2525-K12

ORDER CODE

TOOLMASTER Right Hand Turning Tool Holder PCLNR-2525-K12

	L0501
Part Number - Style	PCLN
Tool Height Size (mm)	25
Clamping Method of Insert	~
Category	~
Connection style	~
Back End Size	~
Application	~
Hand Type	Right
Holder Style	~
Clearance Angle	~
Insert Type	CNMG12
A (H) (mm)	25
B (mm)	25
C (LF) (mm)	150
LH (mm)	~
F (WF) (mm)	32
E (mm)	26