

**TOOLMASTER A32T-PCLNR-12**

**Right Hand Boring Bar**

**Ø32mm**



## TOOLMASTER Right Hand Boring Bar A32T-PCLNR-12



Top View



Side View

### Description

Negative rake boring bar for Heavy duty roughing with 95 degree approx angle. Roughing tool for large metal removal when boring large bores.

Through coolant supplies coolant directly to the insert to cool and washout the swarf

NOTE: Inserts NOT included with tool holders.

Use insert CNMG 120408 (L0602)

### Features

- Positive rake turning tool holder with 90° approach angle
- Suitable for rapid metal removal

### Specifications

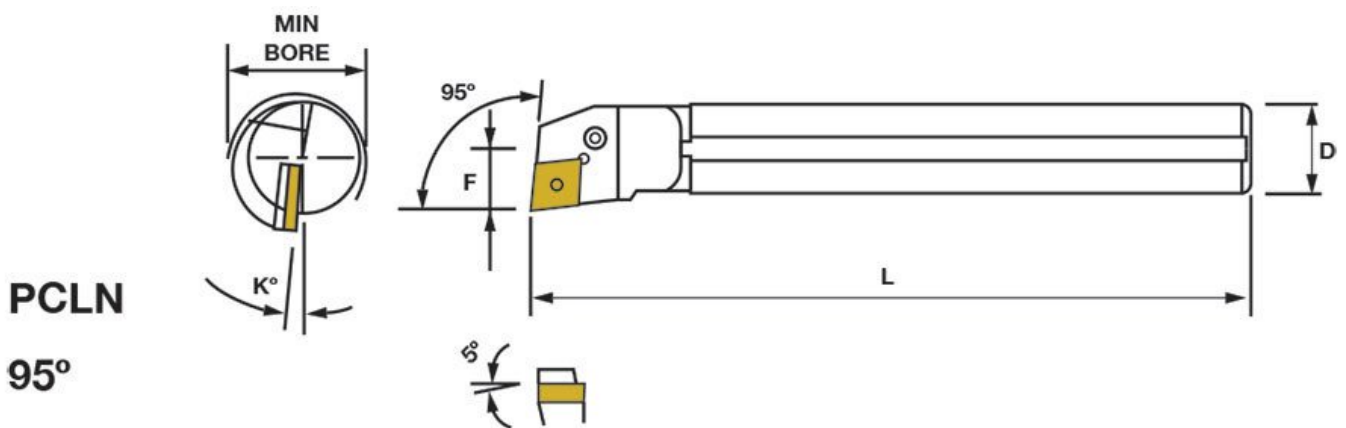

ORDER CODE	L0263
Part Number - Style	~
Size (mm)	32

**TOOLMASTER Right Hand Boring Bar A32T-PCLNR-12**

<b>Hand Type</b>	RIGHT
<b>B = Minimum Bore (mm)</b>	40
<b>D (mm)</b>	32
<b>F (mm)</b>	22
<b>L (mm)</b>	250
<b>K (deg)</b>	11°
<b>Minimum Bore (mm)</b>	40