



TOOLMASTER A25S-PCLNR-12

Right Hand Boring Bar

Ø25mm



TOOLMASTER Right Hand Boring Bar A25S-PCLNR-12



Top View



Side View

Description

Negative rake boring bar for Heavy duty roughing with 95 degree approx angle. Roughing tool for large metal removal when boring large bores.

Through coolant supplies coolant directly to the insert to cool and washout the swarf

NOTE: Inserts NOT included with tool holders.

Use insert CNMG 120408 (L0602)

Features

- Positive rake turning tool holder with 90° approach angle
- Suitable for rapid metal removal

Specifications

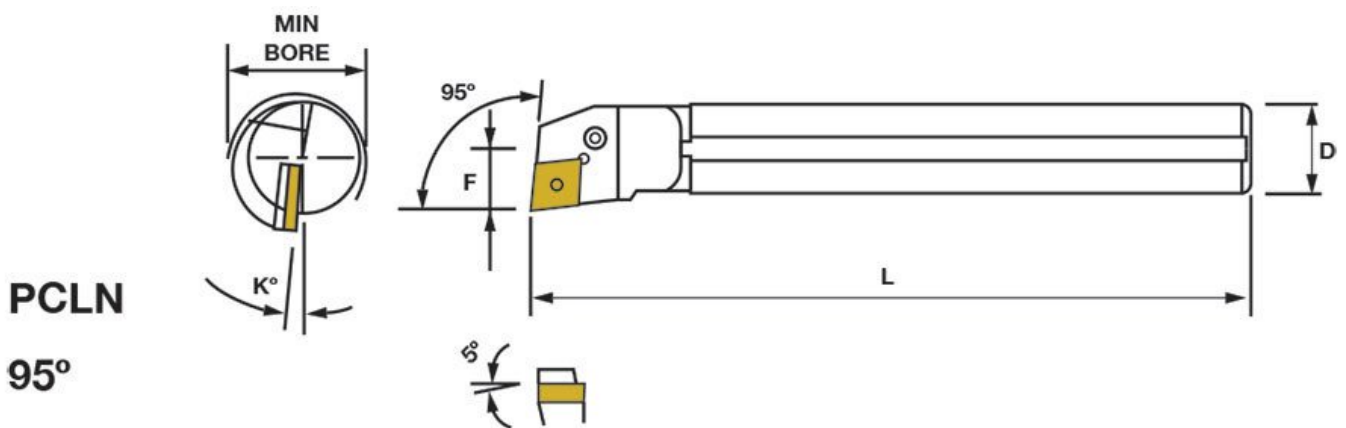

ORDER CODE	L026
Part Number - Style	~
Size (mm)	25

TOOLMASTER Right Hand Boring Bar A25S-PCLNR-12

Hand Type	RIGHT
B = Minimum Bore (mm)	32
D (mm)	25
F (mm)	17
L (mm)	200
K (deg)	11°
Minimum Bore (mm)	32