



**HAFCO CW150S**

**Industrial Caster Wheels**

**Ø150mm Wheels**



## HAFCO Industrial Caster Wheels CW150S



Foot Brake Activated



Foot Brake Released



Top View



Ball Bearings Base with Greasing Nipple



Foot Brake With Swivel Base Lock

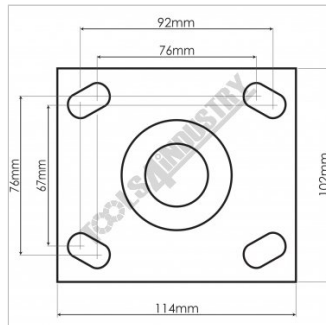

Base Diagram

### Description

Industrial quality Ø150mm caster wheels, Tyre is made from tough elastic rubber with an load capacity of up to 450kg per caster.

### Features

- Ø150mm x 50mm wide steel wheel with bonded polyurethane
- 2 x swivel wheels with brake
- 450kg each wheel capacity
- Brake also locks wheel from swivelling
- Swivel base incorporates ball bearings
- Ball bearing sealed race on main shaft
- Mounting plate 114 x 102mm with 4 slotted holes

### Specifications

<b>ORDER CODE</b>	C414
<b>MODEL</b>	CW-150S
<b>Quantity of Wheels in Pack (No.)</b>	2
<b>Wheel Type</b>	2 Swivel/Brake
<b>Wheel Diameter (mm)</b>	Ø150
<b>Wheel Width (mm)</b>	50
<b>Total Height to Top of Plate (mm)</b>	~
<b>Load Capacity per Wheel (kg)</b>	450
<b>Load Capacity per Set (kg)</b>	900
<b>Nett Weight (kg)</b>	9

**HAFCO Industrial Caster Wheels CW150S**