

HAFCO CW-150



Industrial Caster Wheel Set

Ø150mm Wheels



HAFCO Industrial Caster Wheel Set CW-150



Ball Bearings Base with Greasing Nipple



Foot Brake With Swivel Base Lock



Foot Brake Activated



Foot Brake Released



Top View

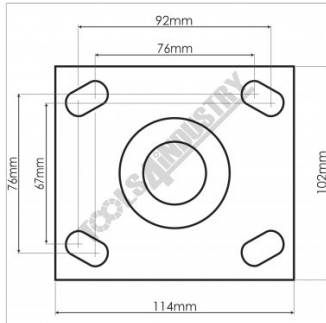

Base Diagram

Description

Industrial quality Ø150mm caster wheels, Tyre is made from tough elastic rubber with an load capacity of up to 450kg per caster.

Features

- Ø150mm x 50mm wide steel wheel with bonded polyurethane
- 2 x fixed wheels
- 2 x swivel wheels with brake
- 450kg each wheel capacity
- Brake also locks wheel from swivelling
- Swivel base incorporates ball bearings
- Ball bearing sealed race on main shaft
- Mounting plate 114 x 102mm with 4 slotted holes

Specifications

ORDER CODE	C413
MODEL	CW-150
Quantity of Wheels in Pack (No.)	4
Wheel Type	2 Fixed, 2 Swivel/Brake
Wheel Diameter (mm)	Ø150
Wheel Width (mm)	50
Total Height to Top of Plate (mm)	~
Load Capacity per Wheel (kg)	450
Load Capacity per Set (kg)	1800

HAFCO Industrial Caster Wheel Set CW-150

Nett Weight (kg)	16
-------------------------	----
