

**HAFCO CW-125**



**Industrial Caster Wheel Set**

**Ø125mm Wheels**



## HAFCO Industrial Caster Wheel Set CW-125



Ball Bearings Base with Greasing Nipple



Foot Brake With Swivel Base Lock



Foot Brake Activated



Foot Brake Released



Top View

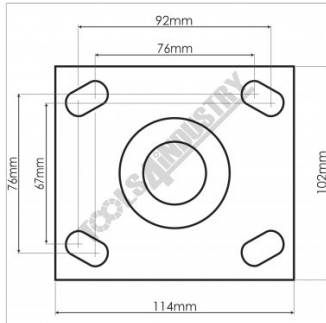

Base Diagram

### Description

Industrial quality Ø125mm caster wheels, Tyre is made from tough elastic rubber with an load capacity of up to 410kg per caster.

### Features

- Ø125mm x 50mm wide steel wheel with bonded polyurethane
- 2 x fixed wheels
- 2 x swivel wheels with brake
- 410kg each wheel capacity
- Brake also locks wheel from swivelling
- Swivel base incorporates ball bearings
- Ball bearing sealed race on main shaft
- 165mm overall height from base of wheel to top of plate
- Mounting plate 114 x 102mm with 4 slotted holes

**HAFCO Industrial Caster Wheel Set CW-125****Specifications**

<b>ORDER CODE</b>	C411
<b>MODEL</b>	CW-125
<b>Quantity of Wheels in Pack (No.)</b>	4
<b>Wheel Type</b>	2 Fixed, 2 Swivel/Brake
<b>Wheel Diameter (mm)</b>	Ø125
<b>Wheel Width (mm)</b>	50
<b>Total Height to Top of Plate (mm)</b>	165
<b>Load Capacity per Wheel (kg)</b>	410
<b>Load Capacity per Set (kg)</b>	1640
<b>Nett Weight (kg)</b>	16