

HAFCO CW-102S



Industrial Caster Wheels

Ø100mm Wheels



HAFCO Industrial Caster Wheels CW-102S



Foot Brake



Top View



Ball Bearing Base With Greasing Nipple

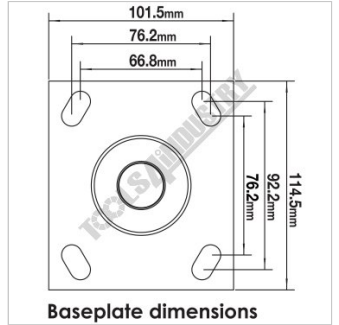

Baseplate Dimensions

Description

Industrial quality Ø100mm caster wheels, Tyre is made from 7mm thick polyurethane with an load capacity of up to 400kg per caster.

Features

- Ø100mm x 50mm wide polyurethane wheel
- 2 x swivel wheels with brake
- 400kg each wheel capacity
- Brake also locks wheel from swivelling
- Swivel base incorporates ball bearings
- Ball bearing sealed race on main shaft
- 145mm overall height from base of wheel to top of plate
- Mounting plate 114.5 x 101.5mm with 4 slotted holes

Specifications

ORDER CODE	C409
MODEL	CW-102S
Quantity of Wheels in Pack (No.)	2
Wheel Type	2 Swivel/Brake
Wheel Diameter (mm)	Ø100
Wheel Width (mm)	50
Total Height to Top of Plate (mm)	145
Load Capacity per Wheel (kg)	400
Load Capacity per Set (kg)	
Nett Weight (kg)	6