

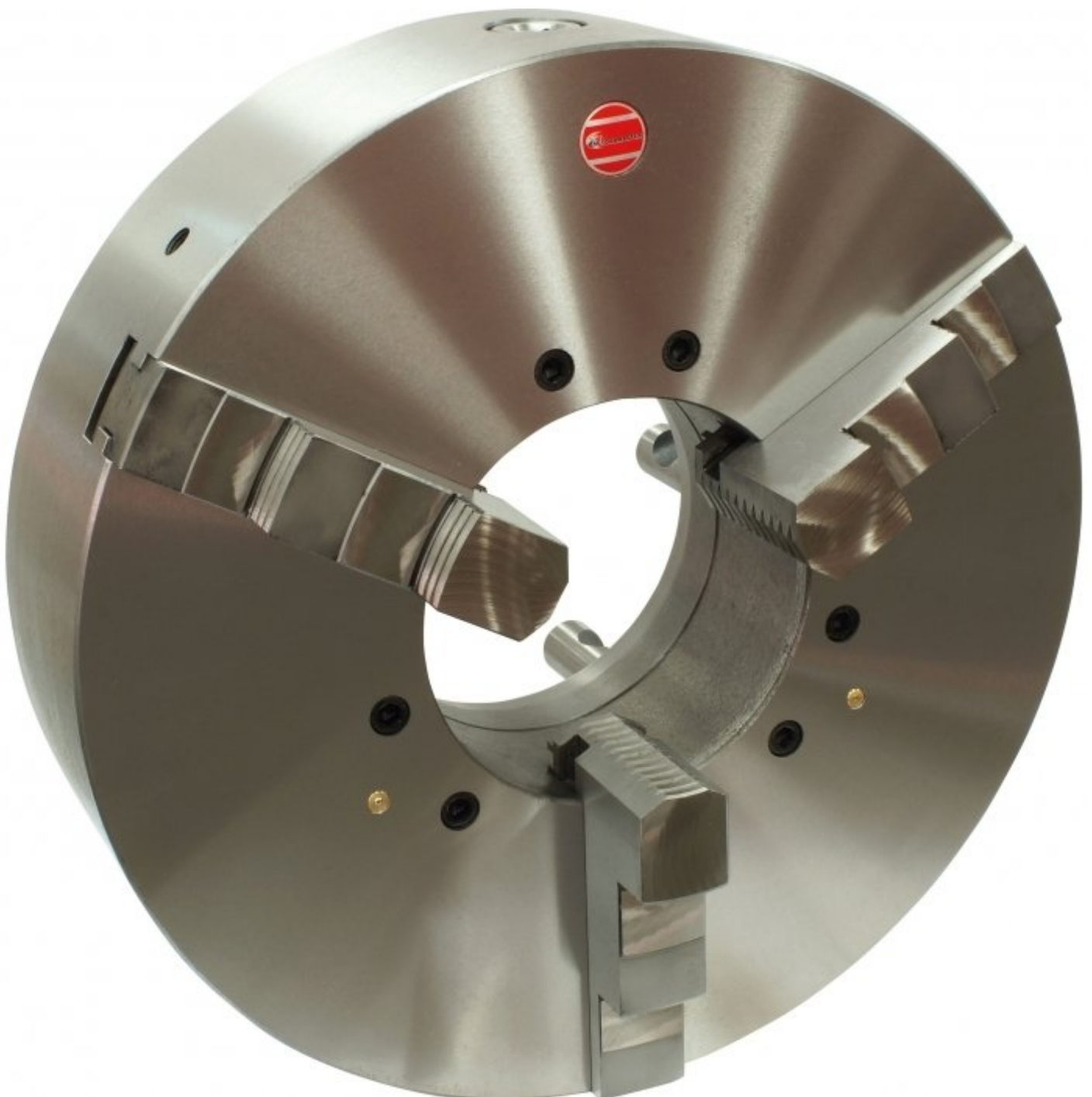

TOOLMASTER K11-500/D11

3 Jaw Self Centring Lathe Chuck

Ø500mm



TOOLMASTER 3 Jaw Self Centring Lathe Chuck K11-500/D11



Front View



Camlock Mount



Included Accessories

Description

K11 SERIES Cast Iron Body
Standard GB/T 4346.2-2002

Features

- World-class and industry leader in the manual lathe chuck field with over 30 years of manufacturing
- ToolMaster quality assurance and accuracy testing ensure standards remain high. ToolMaster is ISO 9001-2000 approved
- Each chuck is supplied with a set of inside and outside jaws and a chuck key

Includes

- Outside jaws
- Inside jaws
- Chuck key

Specifications

TOOLMASTER 3 Jaw Self Centring Lathe Chuck K11-500/D11

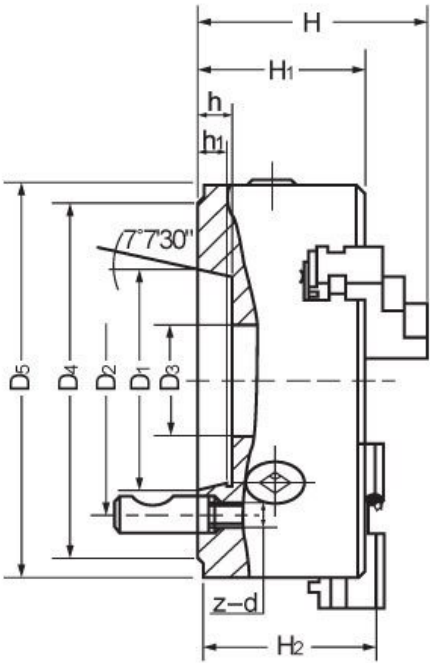

CAMLOCK

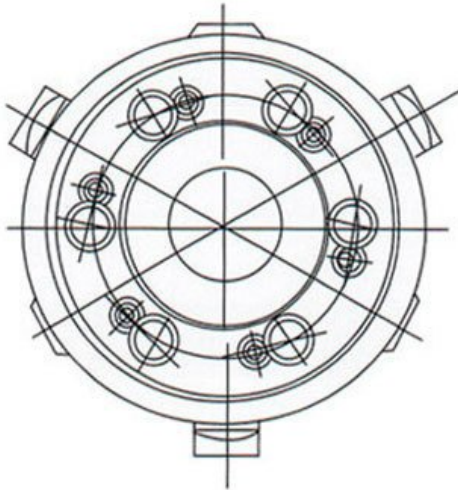

TOOLMASTER 3 Jaw Self Centring Lathe Chuck K11-500/D11

ORDER CODE

TOOLMASTER 3 Jaw Self Centring Lathe Chuck K11-500/D11

C2706

Chuck Size (mm)	Ø500
Camlock	D1-11
Outside Jaw (mm)	11.5 - 210
Inside Jaw (mm)	150 - 500
Speed (rpm)	800
D1 (mm)	196.87
D2 (mm)	235
D3 (mm)	190
H (mm)	222
H1 (mm)	135
h (mm)	20
Nett Weight (kg)	155