

HAFCO FLA-2T-2G

Forklift Jib Attachment

WLL 2 Tonne Capacity



HAFCO Forklift Jib Attachment FLA-2T-2G



Swivel Hook



Tine Opening



Rear View



Front View



Side View



Top View



Top Front View 2



Top Front View 3



Right View



Shown Attached on Forklift



Shown Attached on Forklift 2

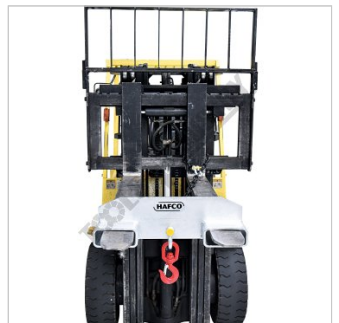

Shown Attached on Forklift 3



1500mm Safety Chain
 Shown on Forklift

HAFCO Forklift Jib Attachment FLA-2T-2G

Description

The FLA-2T Forklift Jib Attachment effectively converts a standard forklift into a versatile mobile crane, enabling operators to lift and manoeuvre awkward or oversized loads that cannot be safely handled with conventional forklift tines. Engineered with an excellent strength-to-weight ratio, this heavy-duty attachment is supplied complete with a safety hook, shackle and safety chain for secure and reliable operation.

The FLA-2T-2G is rated at a Working Load Limit (WLL) of 2 tonne (2000 kg) when correctly positioned and secured on the forklift tines, with the load point located 600 mm from the forklift mast and the safety chain fully attached.

Important:

In accordance with AS 2359.1, forklifts must be de-rated by 20% when using lifting attachments. Ensure the forklift used has a minimum rated capacity of 2.5 tonne before deration to safely support the 2 tonne WLL of this jib attachment -

Features

- Transforms a standard forklift into a versatile mobile crane, ideal for lifting oversized or awkward loads
- Heavy-duty steel construction with excellent strength-to-weight ratio
- Slip-on attachment and safety chain allows quick connection to a forklift
- Hot-dip galvanised finish for superior corrosion resistance and long-lasting durability
- Precision-designed fork pockets for secure and stable engagement
- Supplied complete with Grade 80 swivel safety hook & Safety bow shackle
- Grade 80 Long Link 1.5M Safety chain with bow shackle
- Rated WLL 2 tonne (2000 kg)
- Each attachment is individually serialised and visually inspected and tested
- Designed in accordance with AS 2359.1

Specifications

HAFCO Forklift Jib Attachment FLA-2T-2G

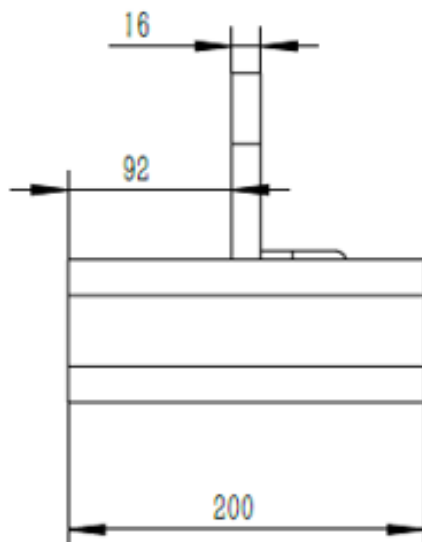
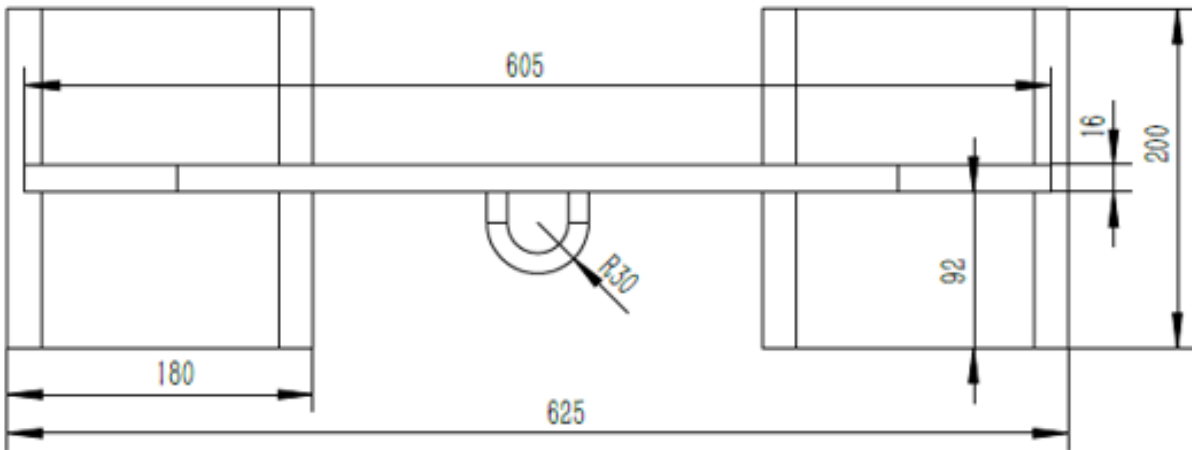
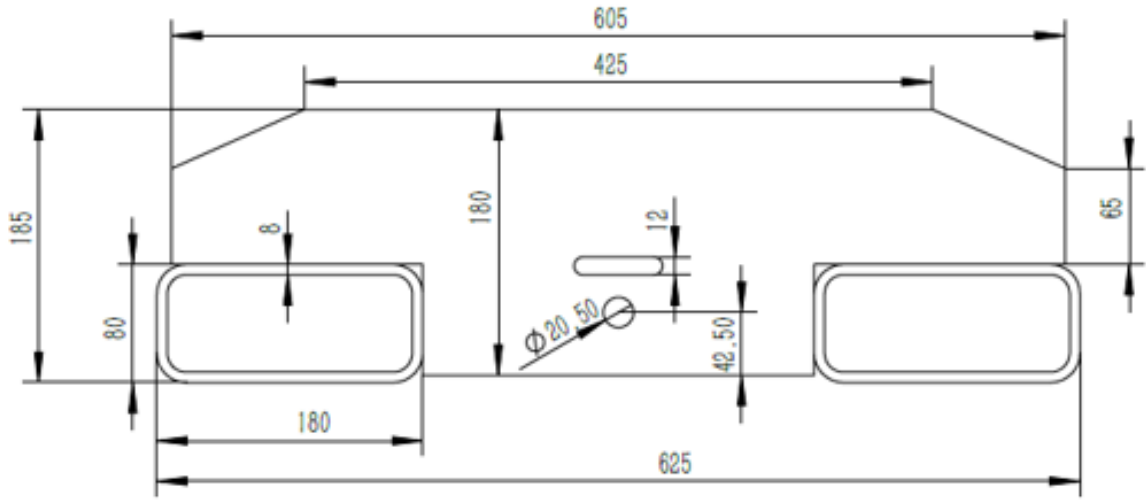

HAFCO Forklift Jib Attachment FLA-2T-2G

ORDER CODE

HAFCO Forklift Jib Attachment FLA-2T-2G

C195

Lifting Capacity (WLL) (Tonne)	2
Width (mm)	625
Safety Chain Length (mm)	1500
Fork Pocket Size (mm)	180 x 80
Fork Pocket Centre (mm)	445
Horizontal Centre of Gravity (HCG) (mm)	312.5 forward from the back edge of the jib
Vertical Centre of Gravity (VCG) (mm)	62
Swivel Hook with Safety Latch (Yes / No)	Yes
Standard (No.)	AS 2359.1
Nett Weight (kg)	25.5